

NC Specifications / FANUC Series

	Item	Specification	0i-TD
Controlled axis	Max. feed axes		4 AXIS
	Feed axes		X/Z/(Cs)
	Max. simultaneously controlled axis		4
Operation functions	Least command increment	0.001mm / 0.0001"	○
	Pulse handle feed	X1, X10, X100	○
	Feedrate per minute	G98	○
Interpolation functions	Feedrate per revolution	G99	○
	Linear interpolation	G01	○
	Circular interpolation	G02, G03	○
	Dwell	G04	○
	Polar coordinate interpolation	G12.1, G13.1	○
	Cylindrical interpolation	G70.1	○
	Variable lead thread cutting	G34	○
	Continuous threading		○
	Reference position return	G28	○
	Reference position return check	G27	○
Feed function	Rapid traverse rate override	F0, 25%, 50%, 100%	○
	Feedrate override		0~150%
Spindle function	Spindle orientation		○
	Rigid tapping		○
Tool functions	Tool number command	T4-Digt / T2-Digt	○
	Tool nose radius compensation	G40 ~ G42	○
	Tool offset pairs		○
	Tool geometry/wear offset	GEOMETRY & WEAR DATA	○
	Tool life management		○
	Tool path graphic display		○
	Automatic tool offset	G36, G37	○
	Direct input of tool offset value measured B		○
Program input	Absolute/incremental programming		○
	Multiple repetitive cycle	G70 ~ G76	○
	Canned cycles	G90, G92, G94	○
	Inch/metric conversion	G20 / G21	○
	Program restart		○
	Retraction for rigid tapping		○
	Max. programmable dimension	±99999.999mm/±9999.9999"	○
	M function	M3 digit	○
	Custom macro		○
	Canned cycle for drilling		○
	Direct drawing dimension programming		○
	Programmable data input	G10	○
	Optional block skip		○
	Workpiece coordinate system	G52 ~ G59	○
	Number of registerable programs		○
Setting and display	Alarm & Operator history display	ALARM & OPERATION DISPLAY	○
	Run hour and parts count display	RUNNING TIME & PART NO. DISPLAY	0~150%
	Display spindle & servo overload	SPINDLE & SERVO LOAD DISPLAY	○
	Self-diagnosis function		○
	Extended part program editing	COPY, MOVE, CHANGE OF NC PROGRAM	○
Data input/output	Display screen		10.4" color
	Memory card input/output		○
Editing operation	USB memory input/output		○
	Part program storage size	512Kbyte(1280m)	○
Manual guide i	Manual Guide i		Option

SMEC

PL 800V/800VM (RH, LH)

VERTICAL TURNING CENTER



SMEC
SMEC CO.,LTD.

SMEC Co., Ltd.

157-10, Goldenroot-ro, Juchon-myeon, Gimhae-si, Gyeongsangnam-do, Korea

Tel +82 55 340 4800 Fax +82 55 340 4740

http://www.esmec.com



SMEC
SMEC CO.,LTD.

- 1988 - Started as Samsung Heavy Industries Machine Tools Business
- 1989 - Horizontal and vertical machining center technology partnership with OKK Japan
- 1991 - Turning center and vertical machining center technology partnership with Mori Seiki
- 1996 - 5-sided processing center technology partnership with Toshiba
- 1999 - Spun out from Samsung Aerospace Industries and established SMEC Co., Ltd

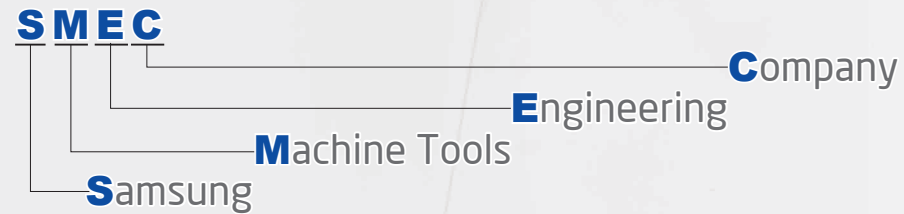

PL 800V PL 800VM

Strongest in class with superb structural design
Simultaneous heavy duty and precision turning

- High speed, precision and high rigidity spindle
- Stable machine structure
- Significantly reduced non-cutting time and high productivity

High Accuracy, High Rigidity Spindle

Main Spindle Structure

High torque main spindle motor is supported by strong Double Cylindrical Roller bearings and Angular Thrust bearings which allow heavy duty cutting and minimize acceleration/deceleration times.

Spindle nose(ASA) : **A2-11**

Spindle bearing diameter(front) : **Ø160mm**

A2-11, 15"~24" chuck available

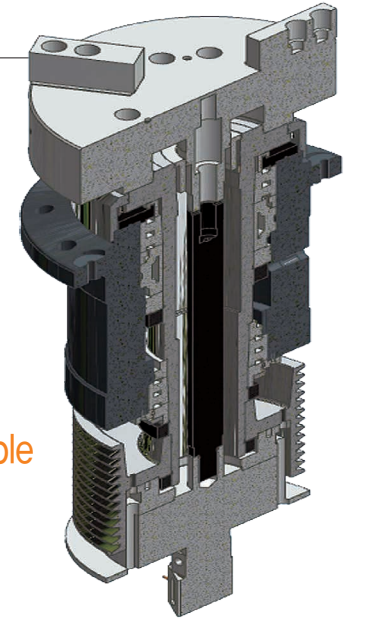

2 Step Gear Box (Opt.)

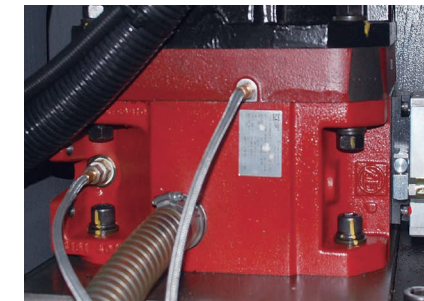

Spindle Power & Torque Diagram

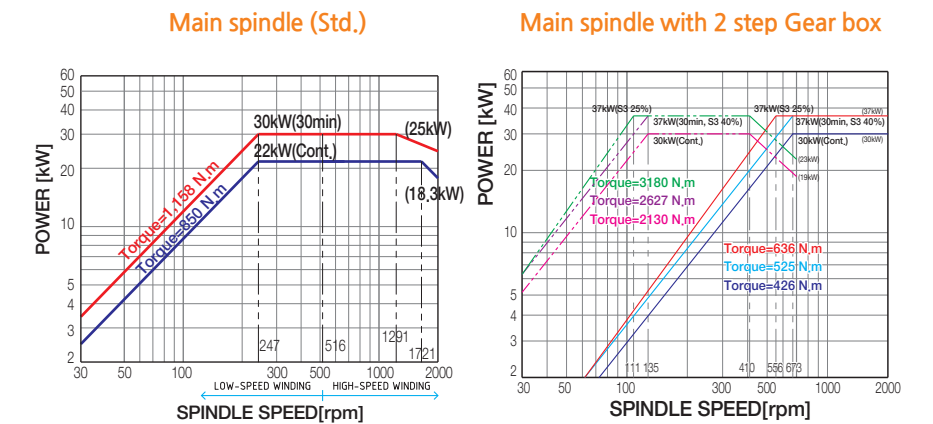

An innovative high precision, heavy duty CNC Lathe, integrated with all of **SMEC's** advanced technology - **PL 800V/800VM**



Spindle speed **2,000 mm** Max. machining diameter **810 mm**
Max. machining length **800 mm** Rapid traverse(X/Z) **20/20 m/min**

Highly Reliable and Rigid Structural Design

Ensure heavy duty and precise cutting with excellent structural design

PL 800V (Standard Turret)

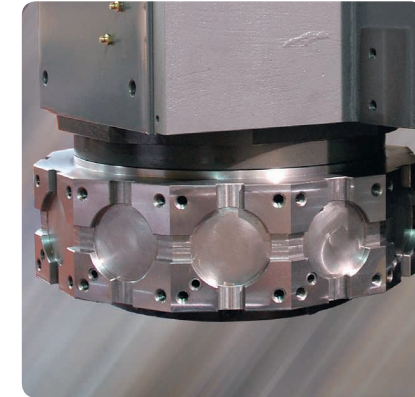

PL 800VM (Mill Turret)



Indexing Time **0.3 sec** Number of tool positions **12 stations**

High Speed, Heavy Duty Servo Turret

Driven by a reliable high torque servo motor, the 12-station heavy-duty turret indexes nonstop, bi-directionally with a fast 0.3 second from station to station. Large diameter 3 pieces precision Curvic coupling with 8,115 kg-f of turret clamping force enables precision as well as heavy-duty cutting.

PL 800VM is equipped with standard 12-station BMT 75 turret, capable of accepting rotary tools at any station.

CLAMP FORCE [HYD. CLAMPING] [SPRING CLAMPING]	kgf	8,063(TOTAL) [8,011(50kgf/cm ²) [52]
---	-----	--

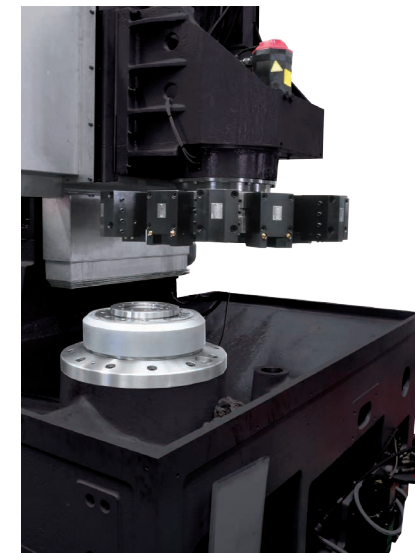

Milling Motor Torque Diagram

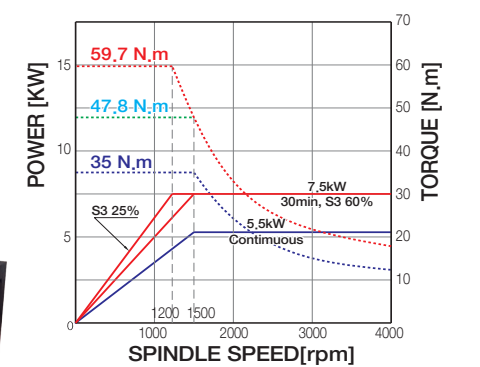



Main Body Construction

The main body of PL 800V/800VM is consisted of one piece meehanite cast iron bed, wide column, anti-heat displacement spindle and headstock, and integral Box way construction with anti-friction mating way surfaces that ensure unsurpassed long term rigidity and superior accuracy.

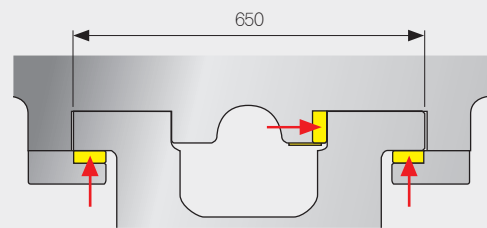

Three(3) adjustable Gibs on X and Z axis provide easier maintenance as well as long term rigidity and accuracy

Column Span : The largest in its class
650mm

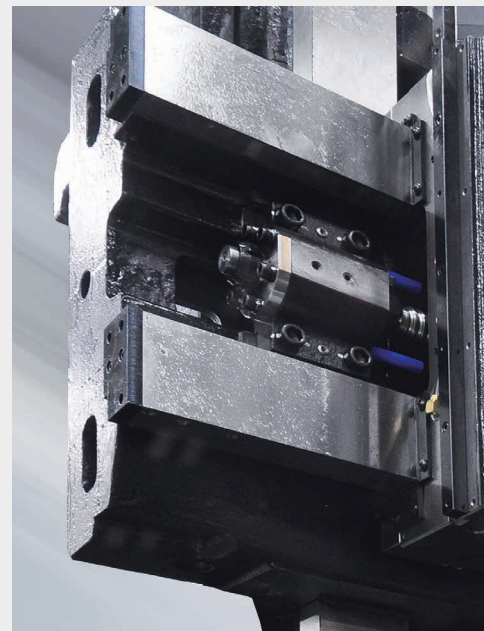

Easy Chip Removal and High Volume Coolant System.

Large volume of flushing coolant allows minimal chip build-up, and slanted splash guard design effectively removes the chip out from the machine.

Motor Discharge Capacity
0.9 kW 300 L/min

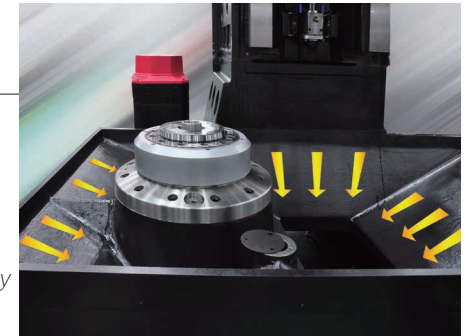

Swivel Operation Panel

Swivel operation panel of 10.4 inch color TFT LCD monitor can turn to 90 degree, providing operators with easy access to the control panel while working on the machine.

Pre-tensioned and Double Anchored Ballscrews



All axes ballscrews are pre-tensioned, heat treated, and fixed by double anchors on both ends, providing ultimate rigidity and minimal thermal growth.

Reliable Lubrication Dispenser

Lubrication pump adopted LUBE which is one of the most reliable brand and offers exact amount of oil on each face.

·Capacity : **3 Liter**
·Pressure : **1.5 Mpa**



High Precision

Surface Roughness

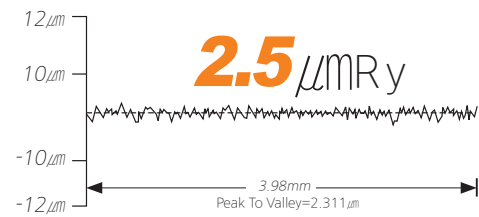

Model : PL 800V

Roundness

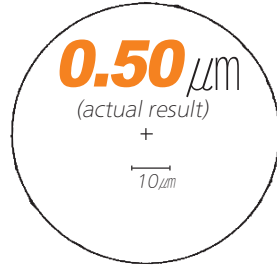

Cutting condition	
Tool	Diamond tool <nose radius 0.020 inch>
Material	AL150<Aluminum>
Cutting speed	198 m/min
Feedrate	0.05 mm/rev
Depth of cut	0.1 mm
Outer diameter	200 mm
Filter	1-50

Processing Speed

Turning Performance (material:SM45C) PL800V

Heavy-duty cutting (O.D) <32mm×32mm qualified tool>

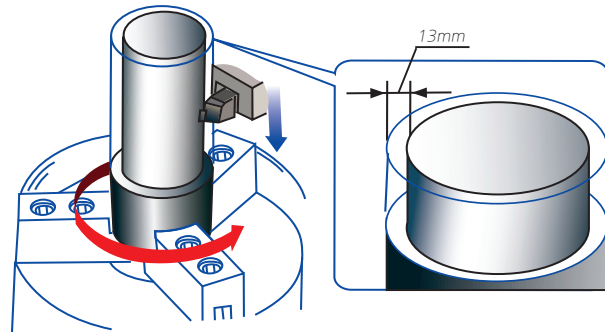

Spindle speed
357 rpm
Cutting speed
142 m/min
Depth of cut
13 mm <Spindle Load 65%>
Feedrate
0.3 mm/rev

Machine Dimensions

Unit : mm

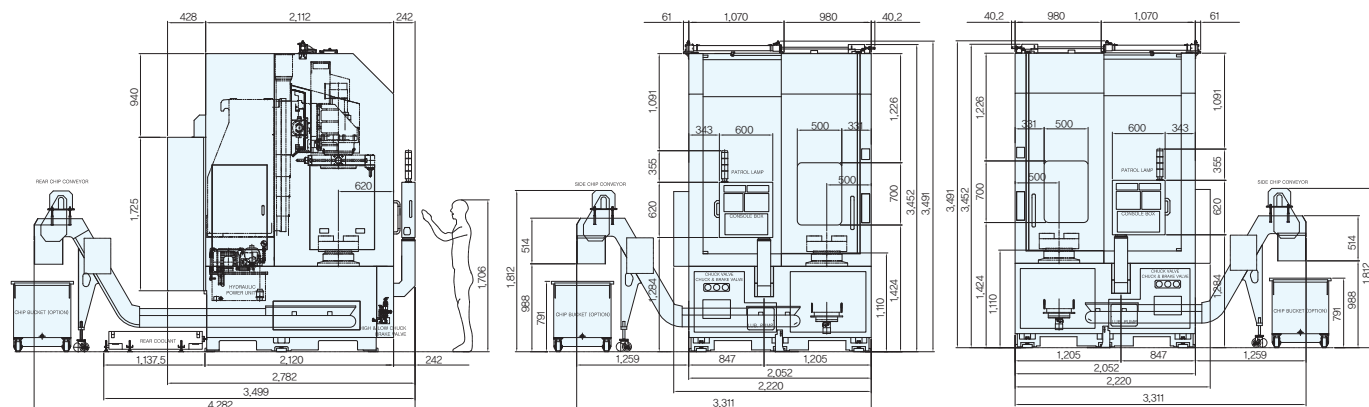

Tool Holders & Sleeves

Unit : mm

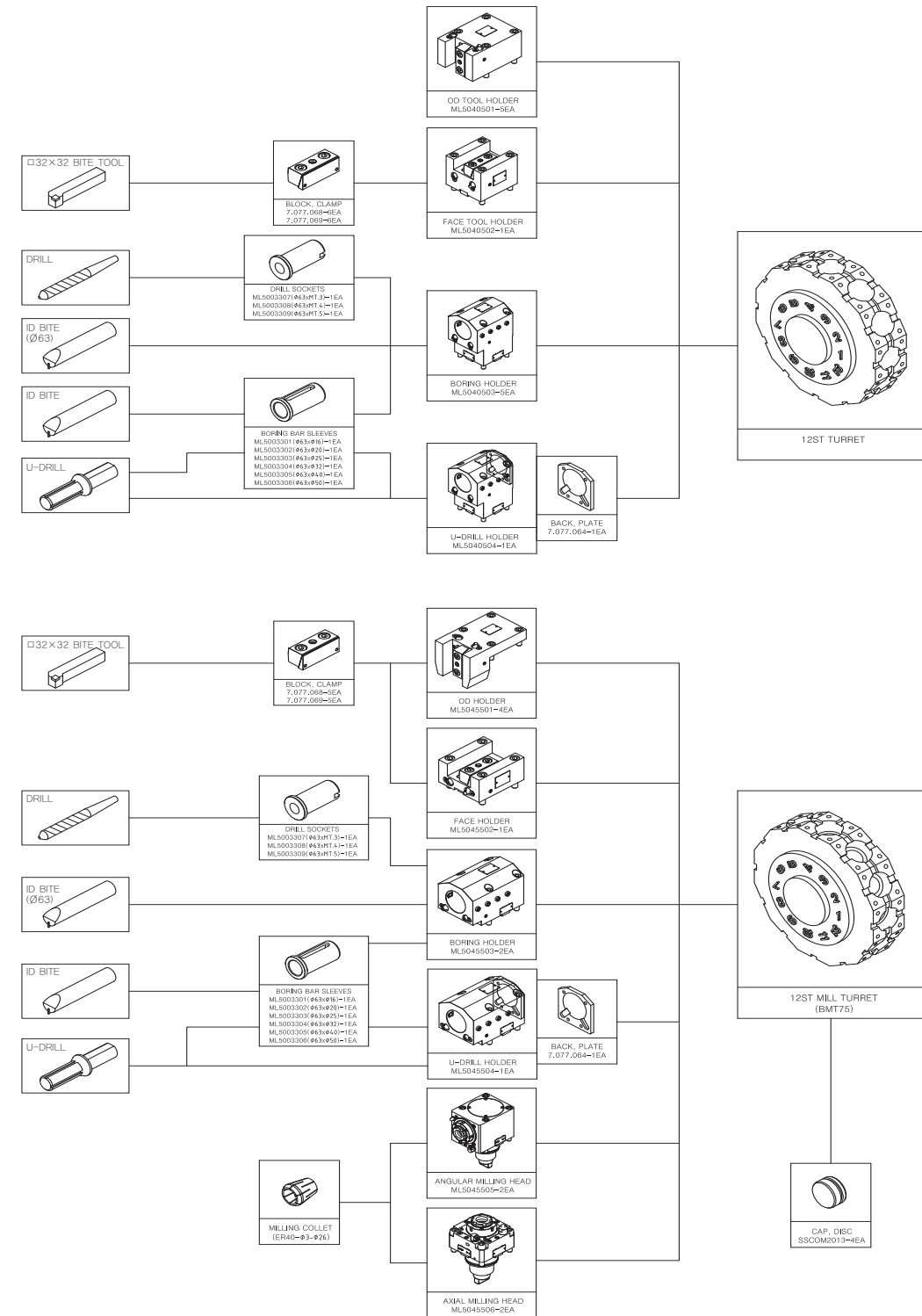

Work Range

Unit : mm

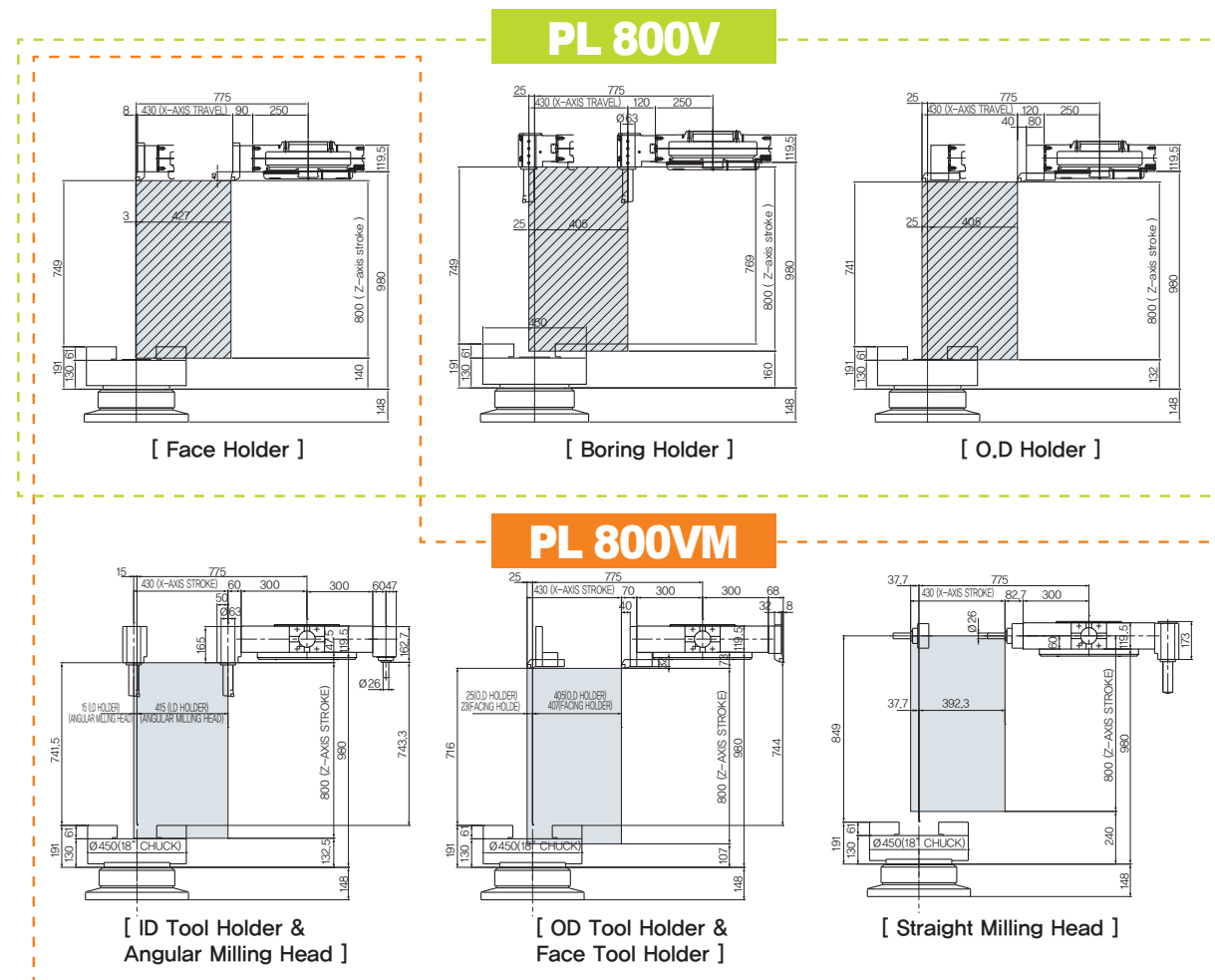

Turret Head Interference

Unit : mm

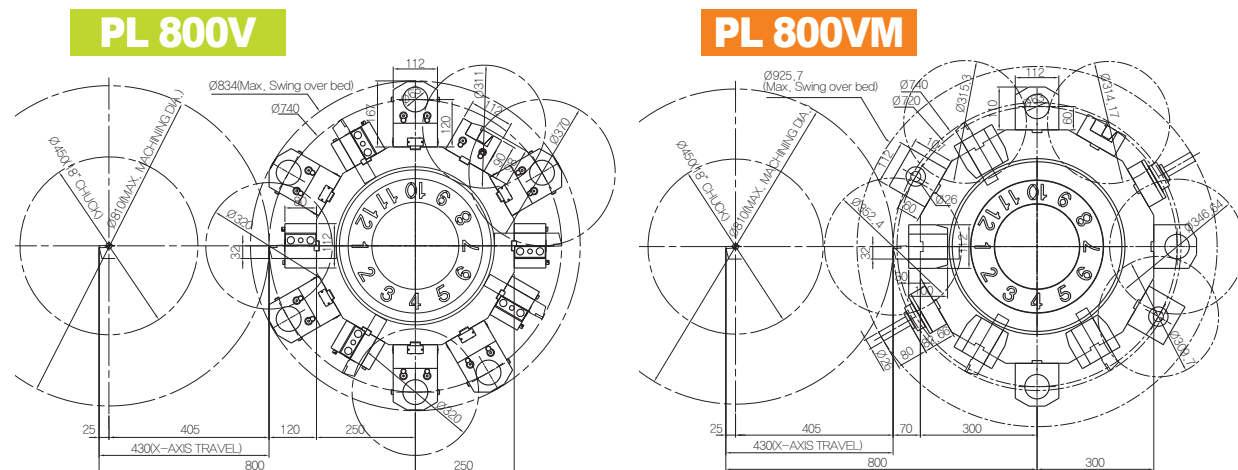

Major Specifications

DESCRIPTION		PL 800V	PL 800VM	
CAPACITY	Swing over bed	mm	Ø890	
	Swing over saddle	mm	Ø740	
	Max. Turning diameter	mm	Ø450	
	Max. Turning length	mm	Ø810	
MAIN SPINDLE	Chuck size	mm	800	
	Spindle speed	m/min	430	
	Spindle nose	mm	800	
	Spindle bearing diameter (Front)	m/min	20/20	
TRAVEL	Spindle drive	-	BOX GUIDE	
	Cs spindle index angle	rpm	2,000	
	X-axis travel	ASA	A2-11	
	Z-axis travel	mm	Ø104	
	Rapid traverse rate (X/Z)	mm	Ø160	
	Guide way type (X/Z)	deg	-	0.001
	Max. number of tool	-	Belt [+Gear Box]	
TOOL POST	OD tool shank size	N.m	1,158/850 [3,180/2,130]	
	Boring bar diameter	ea	12/SERVO Driven	
	Turret clamping force	mm	□ 32	
	Rotary tool size	mm	Ø63	
MOTOR	Rotary tool spindle speed	sec	0.3	
	Indexing time	rpm	-	4,000
	Main spindle motor (Cont./Max.)	kW	30/22 [37/30]	
	Servo motor (X/Z)	kW	4/9	
MOTOR	Rotary tool spindle motor(Cont./Max.)	kW	-	7.5/5.5
	Toolpost rotation motor	kW	1.8	
	Electric power supply	kVA	53 (61)	
Machine dimension (L×W×H)	mm	2,050 × 2,782 × 3,452		
Machine weight	kg	11,000	11,200	
CONTROLLER		Fanuc Oi-TD		

※ Design and specifications subject to change without notice.

() : Option

Standard Accessories

- Coolant unit (4.5bar-60Hz)
- Shower coolant unit (1.5bar-60Hz)
- Work light
- S/G & Rear coolant tank
- Tool & work box
- Hyd. Solid chuck (18")
- Soft jaw (1 set)
- Leveling unit
- Chuck clamp foot switch
- Chuck pressure switch
- 3 Color patrol lamp
- 10.4" LCD monitor
- Auto lubrication pump
- Manual & Parts list
- Safety precaution name plate
- Door interlock

Optional Accessories

- Hard jaw
- Chip conveyor & bucket (side/rear) (Hinge/Scraper)
- Chip bucket
- Special Chuck
- Dual pressure chucking
- Auto-door
- Air gun
- Air blower
- Oil skimmer
- Chuck coolant
- Coolant gun
- Coolant chiller
- Coolant pressure switch
- Coolant level switch
- High pressure coolant (7, 10, 15, 20bar-60Hz)
- Mist collector
- Transformer
- Tool presetter (Removable)
- Linear scale (X,Z)
- Work Counter
- CE Spec.