

■ NC Unit Specifications / FANUC Series

Item	Specification	0i-TD
Controlled axis	Max. feed axes	4 AXIS
	Feed axes	X/Z/(Cs)
	Max. simultaneously controlled axis	4
	Least command increment	0.001mm / 0.0001"
Operation functions	Pulse handle feed	X1, X10, X100
	Feedrate per minute	G98
	Feedrate per revolution	G99
Interpolation functions	Linear interpolation	G01
	Circular interpolation	G02, G03
	Dwell	G04
	Polar coordinate interpolation	G12, 1, G13, 1
	Cylindrical interpolation	G70, 1
	Variable lead thread cutting	G34
	Continuous threading	
	Reference position return	G28
	Reference position return check	G27
Feed function	Rapid traverse rate override	F0, 25%, 50%, 100%
	Feedrate override	0~150%
Spindle function	Spindle orientation	
	Rigid tapping	
Tool functions	Tool number command	T4-Digt / T2-Digt
	Tool nose radius compensation	G40 ~ G42
	Tool offset pairs	
	Tool geometry/wear offset	GEOMETRY & WEAR DATA
	Tool life management	
	Tool path graphic display	
	Automatic tool offset	G36, G37
	Direct input of tool offset value measured B	
Program input	Absolute/incremental programming	
	Multiple repetitive cycle	G70 ~ G76
	Canned cycles	G90, G92, G94
	Inch/metric conversion	G20 / G21
	Program restart	
	Retraction for rigid tapping	
	Max. programmable dimension	±99999.999mm/±9999.9999"
	M function	M3 digit
	Custom macro	
	Canned cycle for drilling	
	Direct drawing dimension programming	
	Programmable data input	G10
	Optional block skip	
	Workpiece coordinate system	G52 ~ G59
Number of registerable programs	400EA	
Setting and display	Alarm & Operator history display	ALARM & OPERATION DISPLAY
	Run hour and parts count display	RUNNING TIME & PART NO. DISPLAY
	Display spindle & servo overload	SPINDLE & SERVO LOAD DISPLAY
	Self-diagnosis function	
	Extended part program editing	COPY, MOVE, CHANGE OF NC PROGRAM
	Display screen	10.4" color
Data input/output	Memory card input/output	
	USB memory input/output	
Editing operation	Part program storage size	512Kbyte(1280m)
Manual guide i	Manual Guide i	

SAMSUNG Machine Tools

PL 20M/25/25M/30 CNC TURNING CENTER



SMEC
SAMSUNG MACHINE TOOLS

SMEC Co., Ltd.

157-10, Goldenroot-ro, Juchon-myeon, Gimhae-si, Gyeongsangnam-do, Korea

Tel +82 55 340 4800 Fax +82 55 340 4740

<http://www.esmec.com>



www.esmec.com

SMEC
SAMSUNG MACHINE TOOLS

SAMSUNG'S Advanced Engineering and Machine Design

- Cast iron structure for superior dampening characteristics and thermal displacement
- Rigid 30 degree slant bed design for heavy-duty machining
- Torque tube design to minimize bending and twisting
- Integrated box ways for long-term rigidity and heavy-duty machining



PL 20M/25/25M/30 is a heavy duty, ultra precision Turning Center, combined with Samsung's advanced technological features.

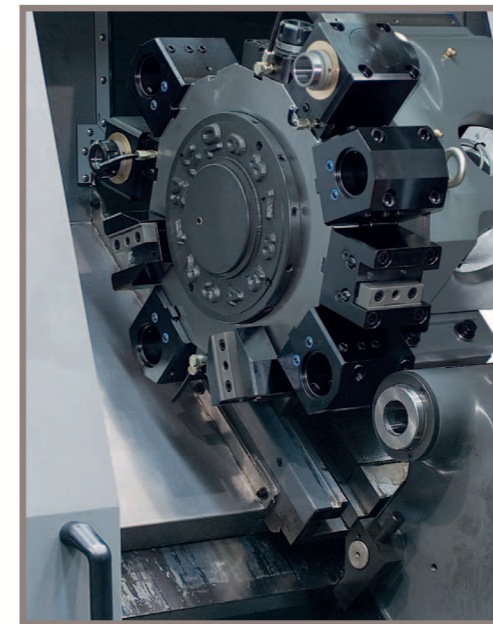

Spindle Speed

4,000 rpm (PL 20LM)

3,500 rpm (PL 25)

2,500 rpm (PL 30)

Spindle Motor(30min/cont.)

15/11 kW (PL 20LM)

22/18.5 kW (PL 25/25LM/30)

Rapid travel(X/Z)

18/24 m/min

Feed Motor(X/Z)

3/3 kW

■ Highly Reliable and Rigid Structural Design

- One piece Meehanite casting with heavily ribbed torque tube design
- Rigid bed supports for powerful cutting
- Excellent vibration dampening and thermal displacement design

Max. Turning Diameter

Ø380 mm (PL 25)

Ø365 mm (PL 20LM/25LM)

Ø400 mm (PL 30)

Max. Turning Length

530 mm (PL 25)

520 mm (PL 25LM)

1,030 mm (PL 25L/30L)

1,020 mm (PL 25LM)

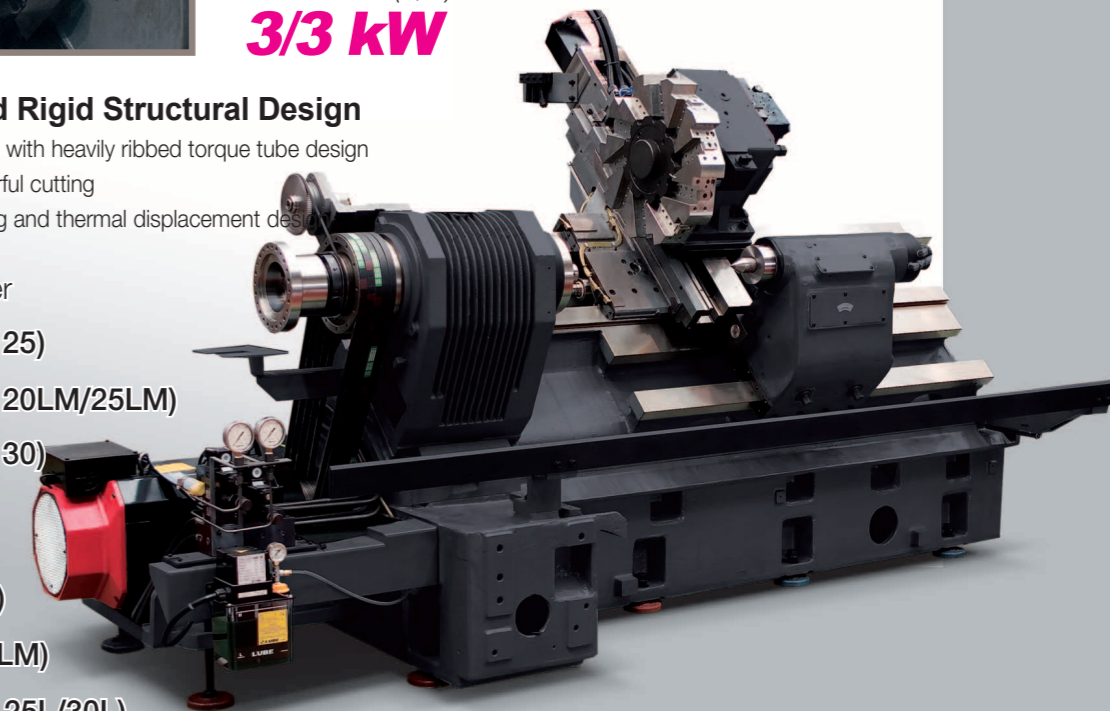

High Accuracy, High Rigidity Spindle

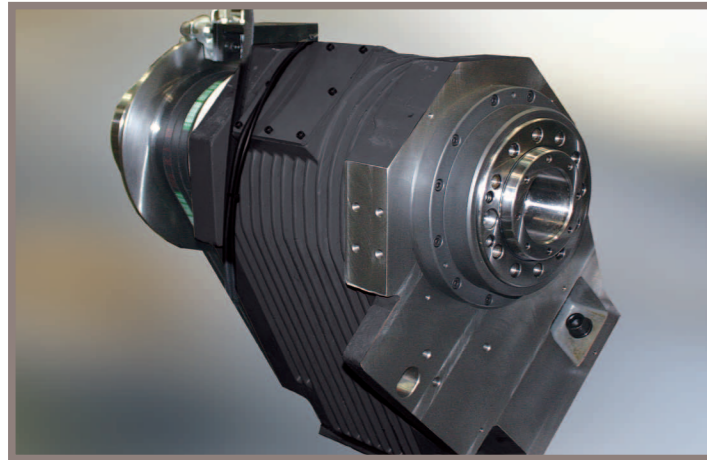

Pin Tube Rib Design for Minimal Axis Heat Transfer

Radiator fan-like pin tube rib design dissipates heat generated by axis movements, maintaining minimal thermal expansion.

C-Axis

With C-axis control, users get synchronized control on 3axes which enables integrated processing, such as milling, drilling & rigid tapping.

SPINDLE & HEADSTOCK

The Spindle and Headstock are machined and ground in temperature controlled environment and assembled in a clean room.

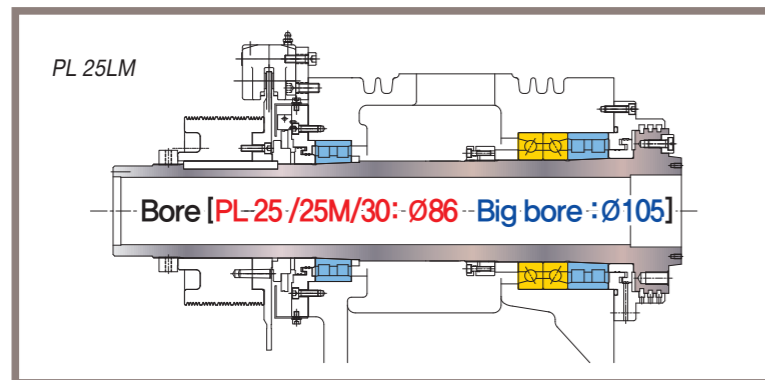

Precision double row cylindrical roller bearings and angular contact ball bearings are located at the front of the spindle, and a double row of cylindrical roller bearings is located in the rear to ensure heavy cutting capabilities with precision.

Spindle Power & Torque Diagram

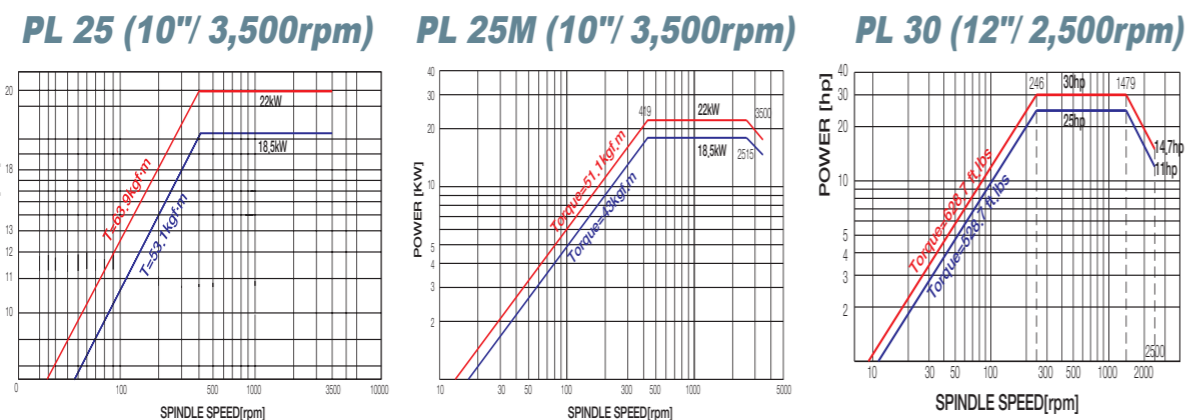

Machine Structure

High Speed, Heavy Duty Hyd. Index Turret

Driven by a high torque hydraulic motor, the 12-station heavy-duty turret can accept tools on both the left and right side of each station. Turret indexing (repeatability $\pm 0,0002''$) is non-stop, bi-directional with a fast 0,25 second next station index time. A large diameter ($\phi 8,27''$) Curvic coupling with 6,404 lbs clamping force enables precision as well as heavy-duty cutting.

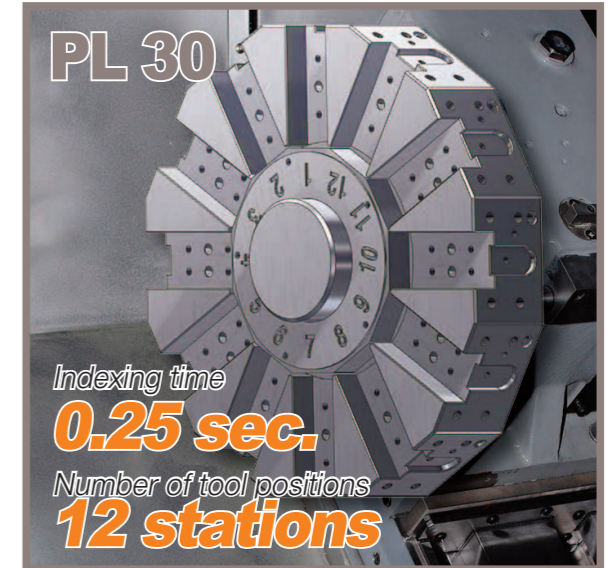

High Speed Servo Turret (BMT Milling Turret)

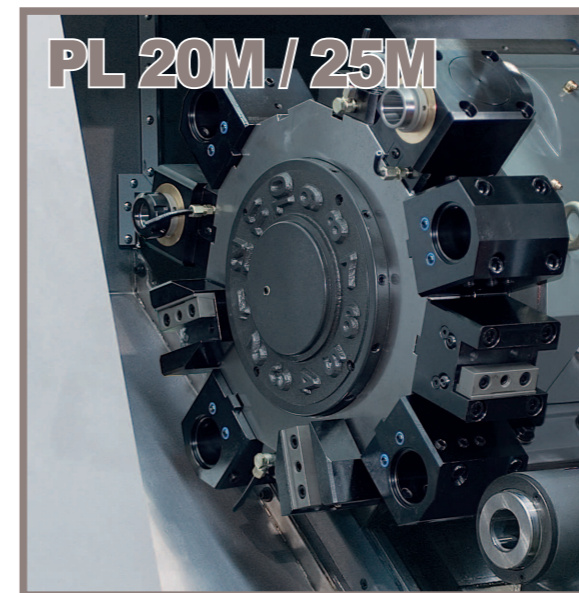

Indexing time **0.2 sec.** Number of tool positions **12 stations**

PL 25LM is equipped with standard 12-station BMT turret capable of accepting rotary tools at any station, providing flexible machining thru various machining operations in just one set-up. Each BMT holder is securely tightened by 4 screws, allowing the turret to perform heavy-duty cutting, milling and drilling operations. Turret indexing is non-stop, bi-directional with a fast 0,2 second next station index time.

Turret Torque Diagram

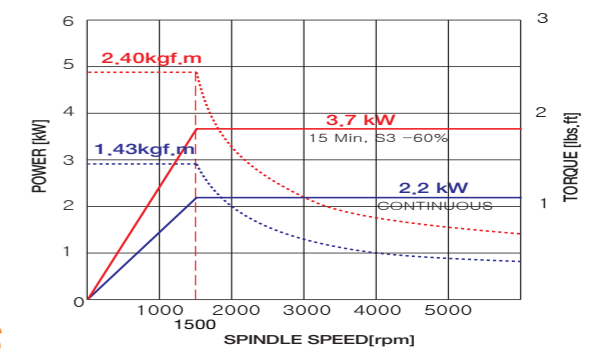

Machine Structure

■ Rigid 45 degree Slant Bed

45 degree slant torque tube design bed and wide guide slide way ensure long term rigidity and machining accuracy.

Featuring superior workability and chip-discharging capability, the bed is designed in a single tube structure boasting strong durability even in heavy-duty cutting.

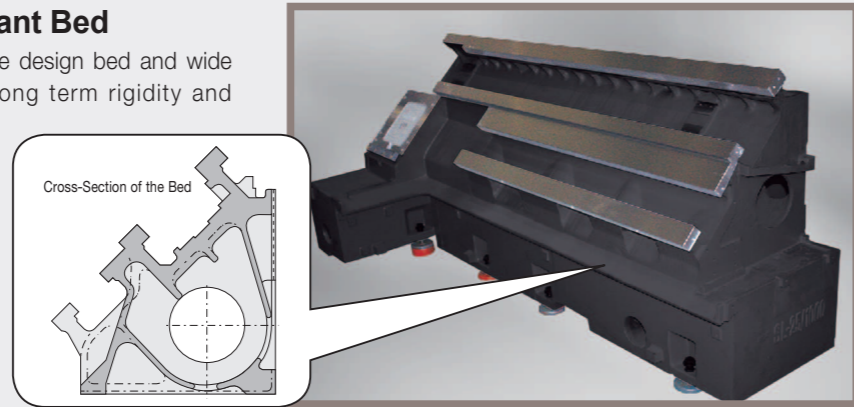

■ Swivel Operation Panel

Swivel operation panel of 10.4 inch color TFT LCD monitor can turn to 90 degree, providing operators with easy access to the control panel while working on the machine.

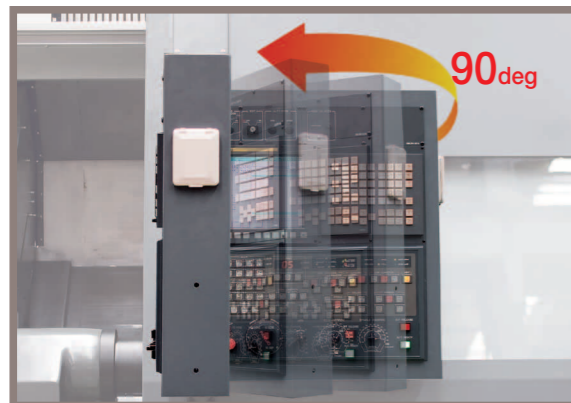

■ Pre-tensioned and Double Anchored Ballscrews

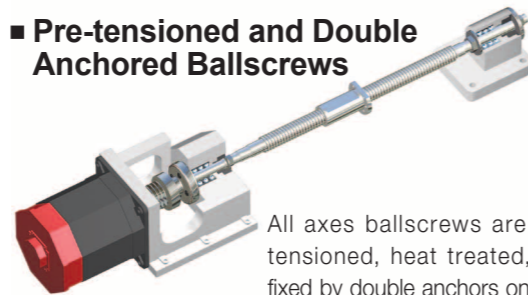

All axes ballscrews are pre-tensioned, heat treated, and fixed by double anchors on both ends, providing ultimate rigidity and minimal thermal growth.

■ Programmable Tailstock [PL 20M/25M:Std.] (carriage direct-coupled)

The programmable tailstock body mounted is on wide guide ways to ensure rigid work piece support.

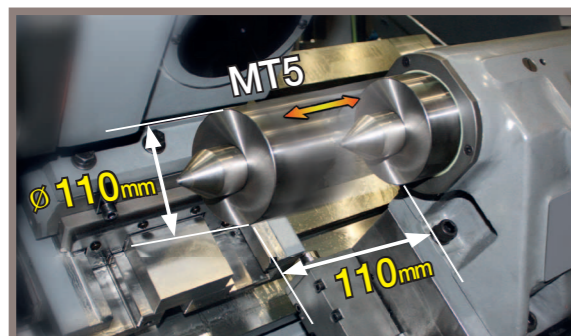

■ Hexahedral Slide Way Frame

Wide integral way is machined from the casting, induction hardened and precision ground to ensure long-term rigidity, machining accuracy and heavy-duty machining.

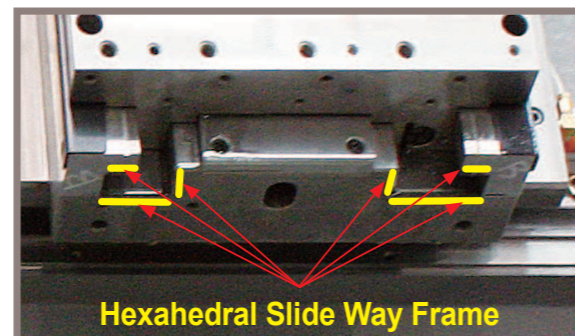

■ High Precision

■ Surface Roughness (O.D. cutting)

■ Roundness

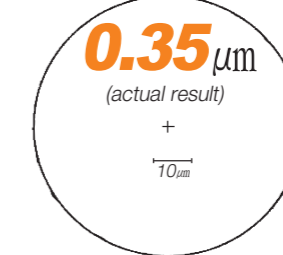
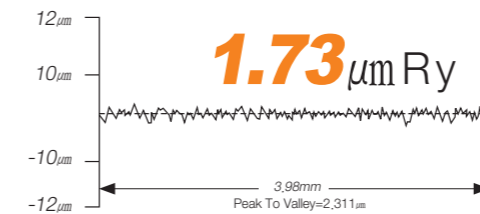

Cutting condition	
Tool	Diamond tool (nose radius 0.020 inch)
Material	AL150 (Aluminum)
Cutting speed	230 m/min
Feedrate	0.05 mm/rev
Depth of cut	0.1 mm
Outer diameter	φ 200 mm
Filter	1-50

•Model : PL 30

■ Processing Speed

■ Turning Performance (material:SM45C) PL 30

Heavy-duty cutting (O.D) (1 inch × 1 inch qualified tool)

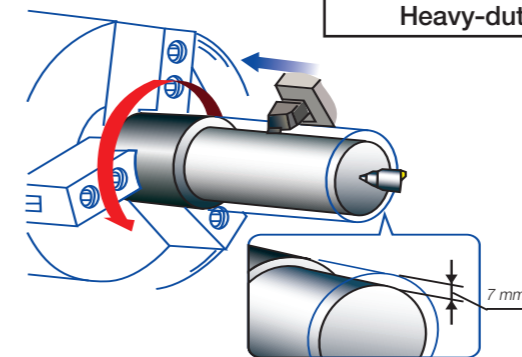

Spindle speed
940 rpm
Cutting speed
130 m/min (426 fpm)
Depth of cut
7 mm <Spindle Load 50%>
Feedrate
0.3 mm/rev (0.08 ipr)

■ Standard Accessories

■ Optional Accessories

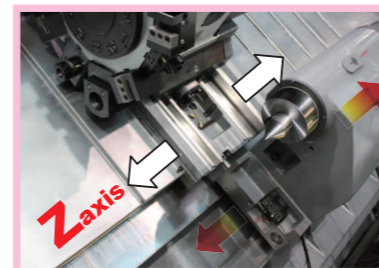

Programmable Tailstock

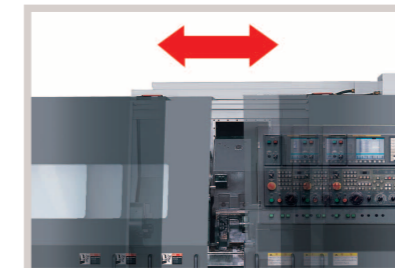

Auto Door

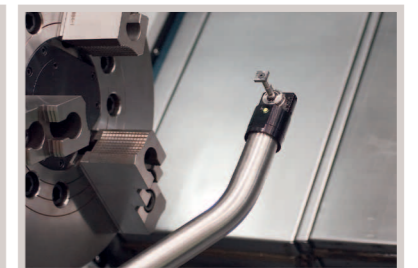

Tool Presetter



Automatic Lubricator



Chip Conveyor

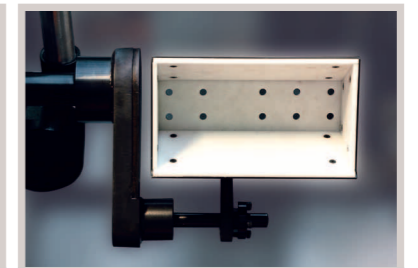

Parts Catcher

■ Tooling System

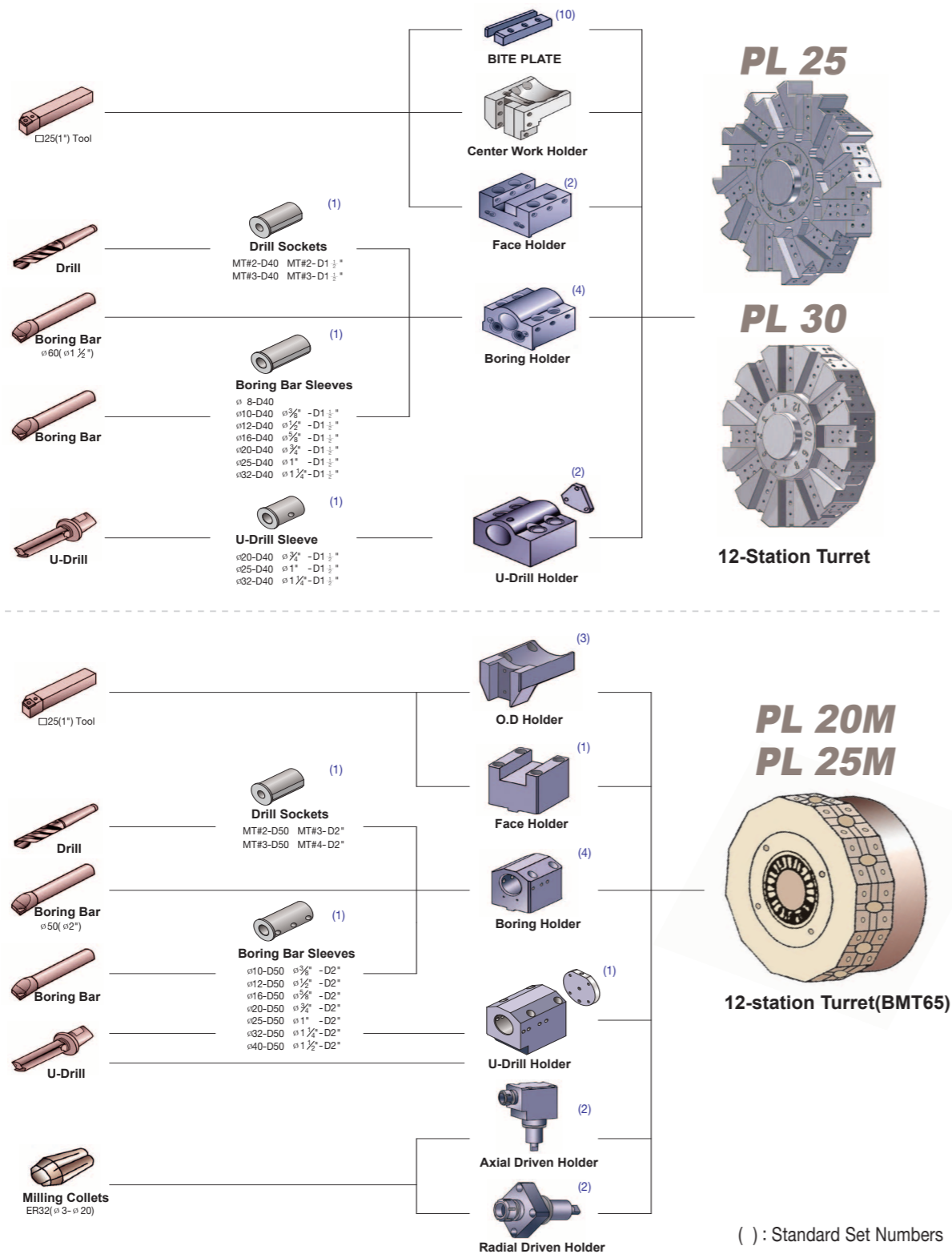

() : Standard Set Numbers

■ Machine Dimensions

Unit : mm

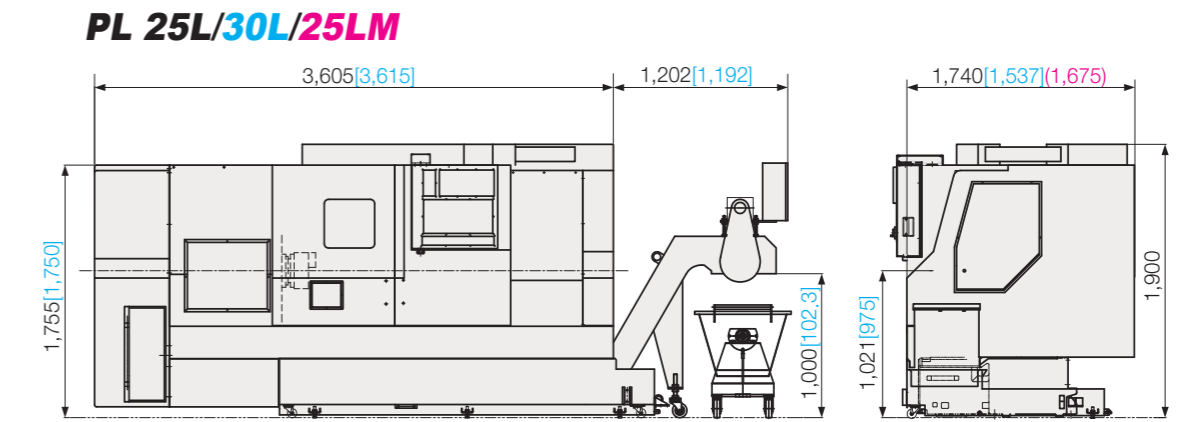
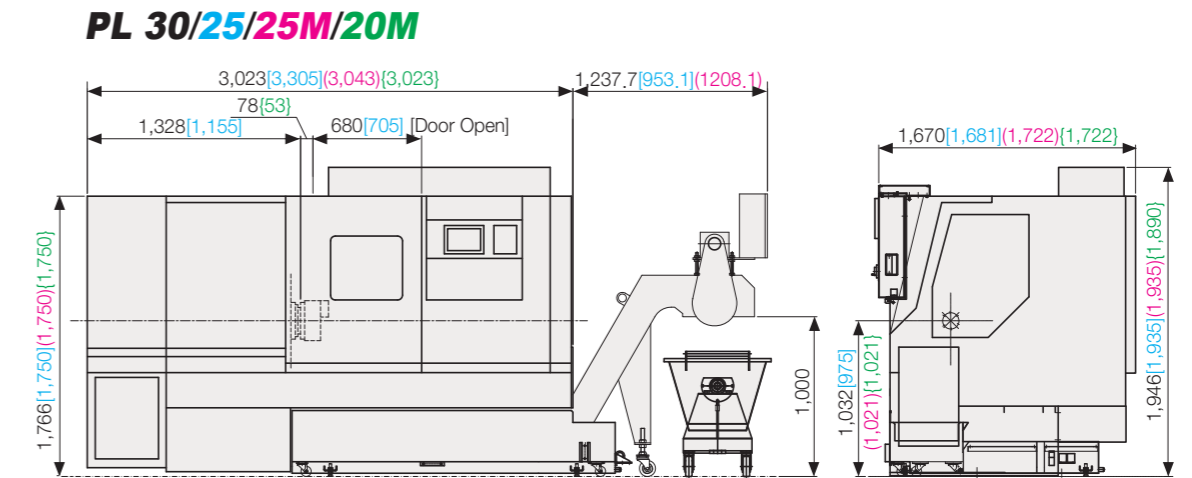

■ Work Range

Unit : mm

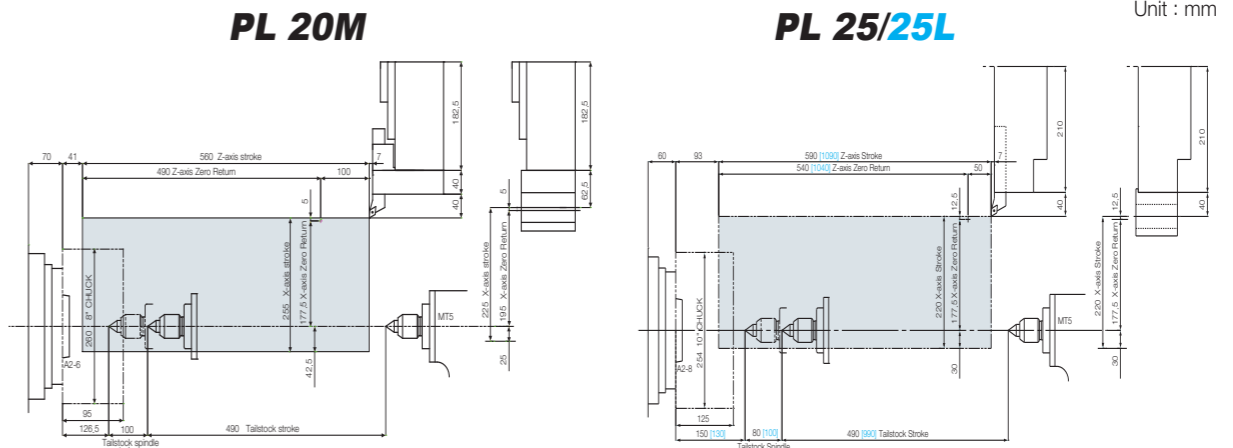

■ Work Range

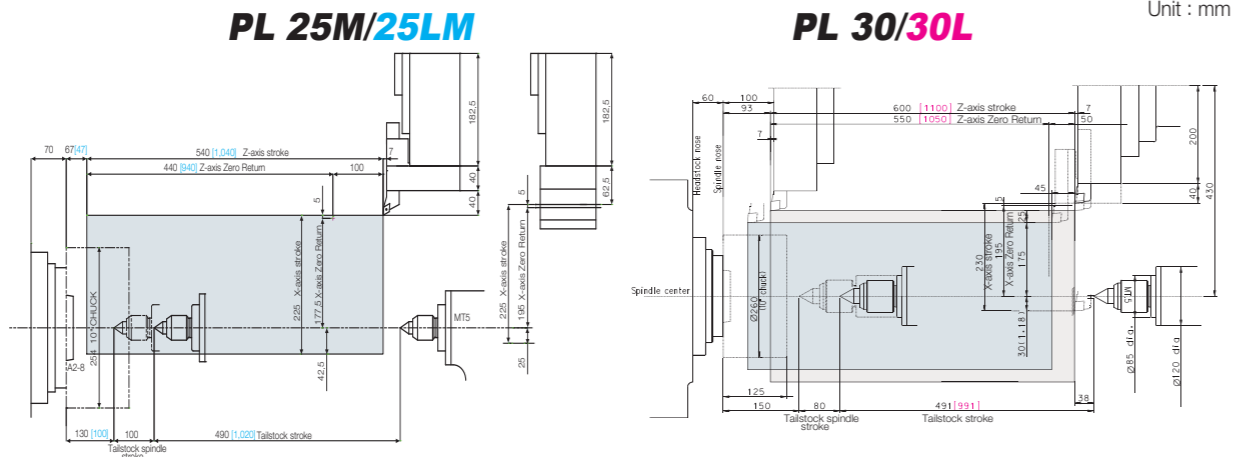

■ Turret Head Interference

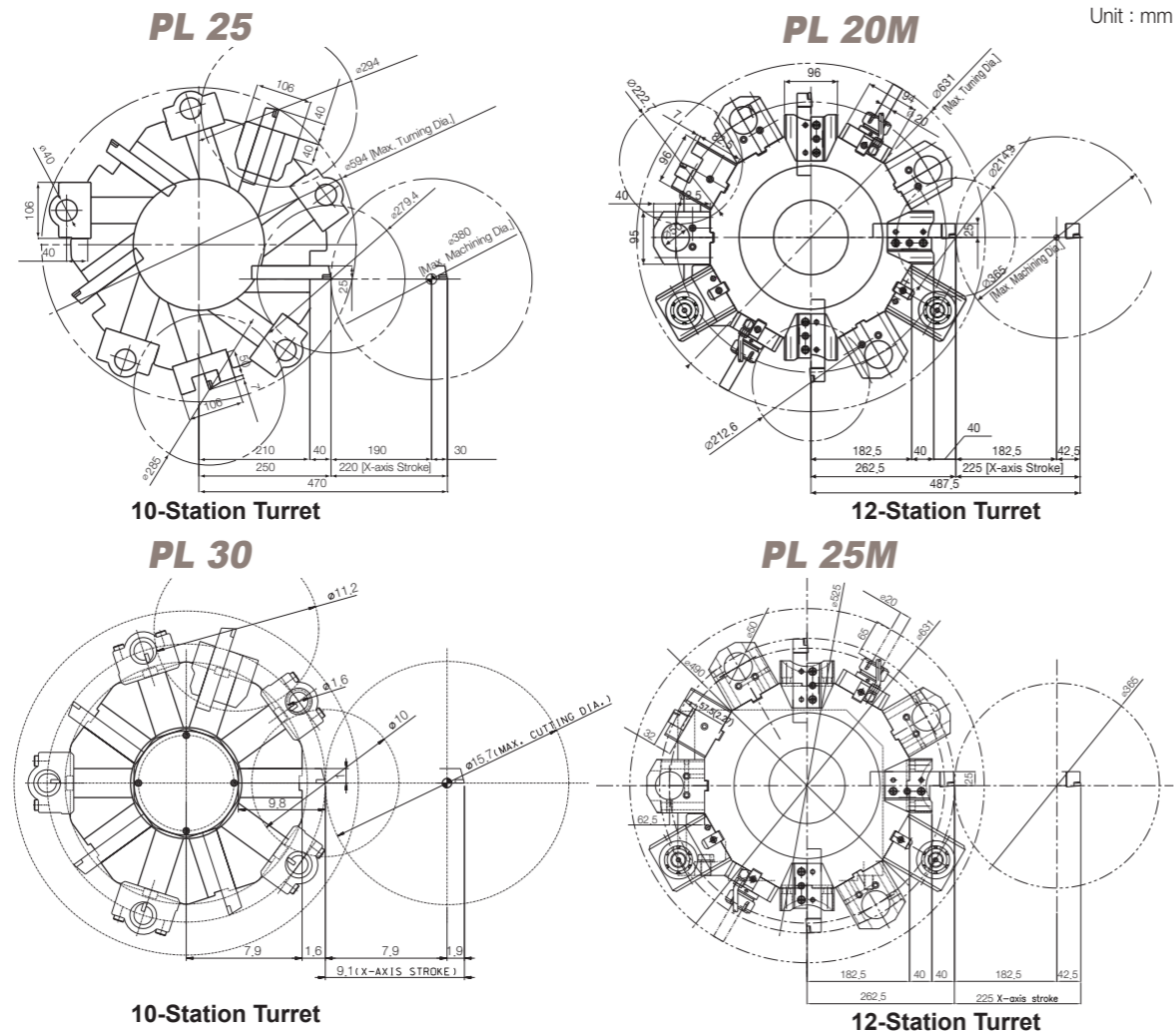

■ Major Specifications

DESCRIPTION		PL20M	PL25	PL25L	PL25M	PL25LM	PL30	PL30L	
CAPACITY	Swing over the bed	mm	∅ 650	∅ 520	∅ 650				
	Swing over the cross slide	mm	480	350	480				
	Max. machining diameter	mm	∅ 365	∅ 380	∅ 365		∅ 400		
	Max. machining length	mm	520	530	1,030	520	1,020	550	1,050
MAIN SPINDLE	Chuck size	inch	10						
	Speed	rpm	4,000	3,500			3,500 (Big Bore:2,500)		
	Spindle nose	ASA	A2-6		A2-8				
	Bore diameter	mm	∅ 78	∅ 86			∅ 86 (Big Bore: ∅ 105)		
	Draw tube I.D.	mm	66	77			77 (Big Bore:91)		
	Motor(30min/cont.)	kW	15/11	22/18.5					
TRAVEL	X/Z axis travel	mm	225/540	220/590	220/1,090	225/540	225/1,040	230/600	230/1,100
	X/Z rapid traverse rate	m/min	18/24	18/24					
	X/Z feed motor	kW	3/3	3/3					
TURRET	Number of tool positions	st.	12	10(12)		12		10(12)	
	Indexing time	sec	0.20	0.25		0.2		0.25	
	Shank size for square tool	mm	□25		□25				
	Shank diameter for boring bar	mm	∅ 50		∅ 50				
	Live tool speed	rpm	4,500	-		4,500		-	
	Milling motor	mm	3.7 / 2.2	-		3.7 / 2.2		-	
TAILSTOCK	Tailstock quill travel	mm	100	80(100)	100	100	80(100)	100	
	Tailstock quill diameter	mm	110	85(110)	110	110	85(110)	110	
ELECTRIC POWER SUPPLY	kVA/V	39 / 220	39 / 220						
REQUIRED FLOOR SPACE	mm	3,190×1,675	3,305×1,681	3,880×1,681	3,300×1,722	3,800×1,722	3,305×1,740	3,880×1,740	
MACHINE WEIGHT	kg	5,100	5,000	6,200	5,300	6,600	5,100	6,500	
CONTROLLER		Fanuc Oi-TD							

• Figures in inches are converted from metric measurements.
• Design and specifications subject to change without notice.

■ Standard Accessories

- COOLANT SYSTEM
- BUILT-IN WORK LIGHT
- SPLASH GUARD
- HAND TOOLS
- TOOL HOLDER
- 8 " HYDRAULIC CHUCK (PL 20M)
- 10 " HYDRAULIC CHUCK (PL 25)
- 12 " HYDRAULIC CHUCK (PL 30)
- SOFT JAWS 3 SETS
- LEVELING BLOCK
- PROGRAMMABLE TAILSTOCK (PL 20M, PL 25M)

■ Optional Accessories

- HARD JAWS 1 SET
- CHIP CONVEYOR
- PARTS CATCHER
- AUTO DOOR
- AIR BLOW UNIT
- AUTO MEASURING SYSTEM
- PROGRAMMABLE TAILSTOCK (PL 25, PL 30)
- TOOL PRESETTER