

NC Specifications / FANUC Series

| | Item | Specification | 0i-TD |
|-------------------------|--|----------------------------------|-------------|
| Controlled axis | Max. feed axes | | 4 AXIS |
| | Feed axes | | X/Z/(Cs) |
| | Max. simultaneously controlled axis | | 4 |
| | Least command increment | 0.001mm / 0.0001" | ○ |
| Operation functions | Pulse handle feed | X1, X10, X100 | ○ |
| | Feedrate per minute | G98 | ○ |
| | Feedrate per revolution | G99 | ○ |
| Interpolation functions | Linear interpolation | G01 | ○ |
| | Circular interpolation | G02, G03 | ○ |
| | Dwell | G04 | ○ |
| | Polar coordinate interpolation | G12.1, G13.1 | ○ |
| | Cylindrical interpolation | G70.1 | ○ |
| | Variable lead thread cutting | G34 | ○ |
| | Continuous threading | | ○ |
| | Reference position return | G28 | ○ |
| Feed function | Reference position return check | G27 | ○ |
| | Rapid traverse rate override | F0, 25%, 50%, 100% | ○ |
| Spindle function | Feedrate override | | 0~150% |
| | Spindle orientation | | ○ |
| Tool functions | Rigid tapping | | ○ |
| | Tool number command | T4-Digt / T2-Digt | T4-Digt |
| | Tool nose radius compensation | G40 ~ G42 | ○ |
| | Tool offset pairs | | ○ |
| | Tool geometry/wear offset | GEOMETRY & WEAR DATA | ○ |
| | Tool life management | | ○ |
| | Tool path graphic display | | ○ |
| | Automatic tool offset | G36, G37 | ○ |
| Program input | Direct input of tool offset value measured B | | ○ |
| | Absolute/incremental programming | | ○ |
| | Multiple repetitive cycle | G70 ~ G76 | ○ |
| | Canned cycles | G90, G92, G94 | ○ |
| | Inch/metric conversion | G20 / G21 | ○ |
| | Program restart | | ○ |
| | Retraction for rigid tapping | | ○ |
| | Max. programmable dimension | ±99999.999mm/±9999.9999" | ○ |
| | M function | M3 digit | ○ |
| | Custom macro | | ○ |
| | Canned cycle for drilling | | ○ |
| | Direct drawing dimension programming | | ○ |
| | Programmable data input | G10 | ○ |
| | Optional block skip | | ○ |
| | Workpiece coordinate system | G52 ~ G59 | ○ |
| Setting and display | Number of registerable programs | | 400EA |
| | Alarm & Operator history display | ALARM & OPERATION DISPLAY | ○ |
| | Run hour and parts count display | RUNNING TIME & PART NO. DISPLAY | ○ |
| | Display spindle & servo overload | SPINDLE & SERVO LOAD DISPLAY | ○ |
| | Self-diagnosis function | | ○ |
| | Extended part program editing | COPY, MOVE, CHANGE OF NC PROGRAM | ○ |
| Data input/output | Display screen | | 10.4" color |
| | Memory card input/output | | ○ |
| Editing operation | USB memory input/output | | ○ |
| | Part program storage size | 512Kbyte(1280m) | ○ |
| Manual guide i | Manual Guide i | | ○ |

SMEC

PL 35/35M/40

CNC TURNING CENTER



SMEC
SMEC CO.,LTD.

SMEC Co., Ltd.

157-10, Goldenroot-ro, Juchon-myeon, Gimhae-si, Gyeongsangnam-do, Korea

Tel +82 55 340 4800 Fax +82 55 340 4740

http://www.esmec.com



SMEC
SMEC CO.,LTD.

- 1988 - Started as Samsung Heavy Industries Machine Tools Business
- 1989 - Horizontal and vertical machining center technology partnership with OKK Japan
- 1991 - Turning center and vertical machining center technology partnership with Mori Seiki
- 1996 - 5-sided processing center technology partnership with Toshiba
- 1999 - Spun out from Samsung Aerospace Industries and established SMEC Co., Ltd

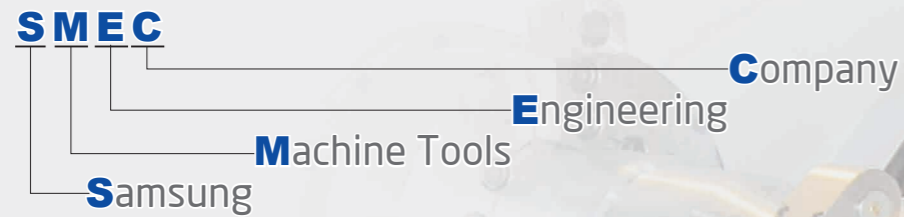

- PL 35
- PL 35L
- PL 35M
- PL 35LM
- PL 40
- PL 40L

Strongest in class with superb structural design
 Simultaneous heavy duty and precision turning

- 45 degree torque tube type bed to support heavy duty turning
- Significantly reduced non-cutting time and efficient turning
- Low-center of gravity reducing vibration, thermal deformation and improving rigidity

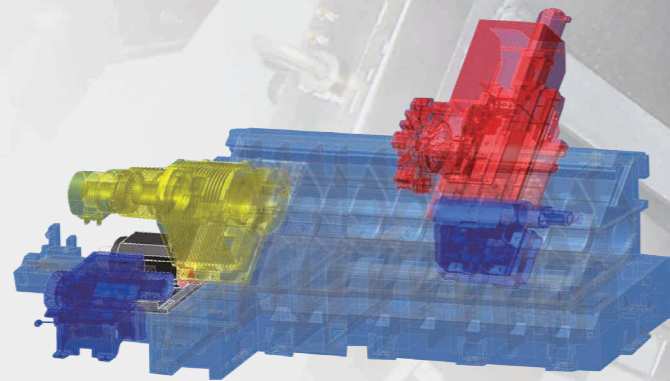

High Accuracy, High Rigidity Spindle

Pin Tube Rib Design for Minimal Axis Heat Transfer

Radiator fan-like pin tube rib design dissipates heat, maintaining minimal thermal expansion.

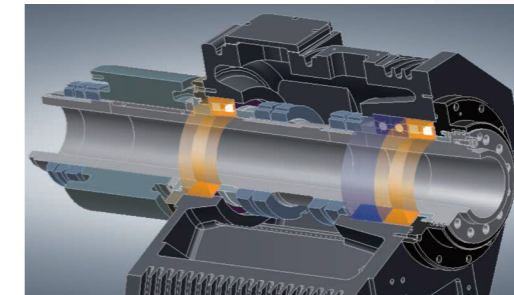
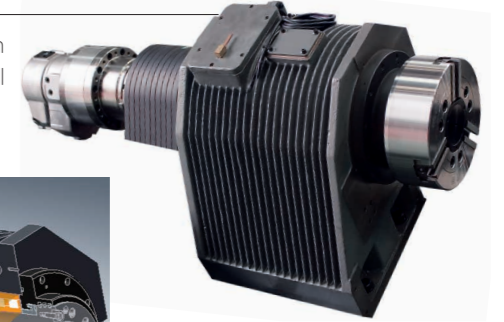

Output Converting Transmission

Equipped as standard feature, high Output Converting Transmission provides heavy-duty machining.

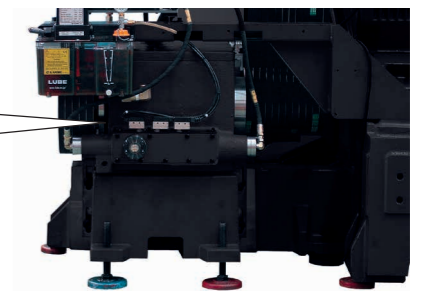
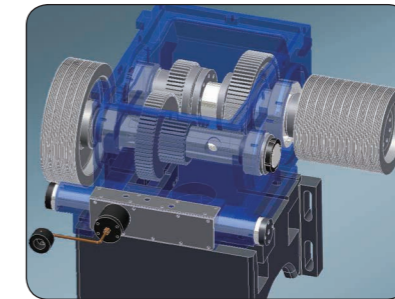

Spindle Power & Torque Diagram

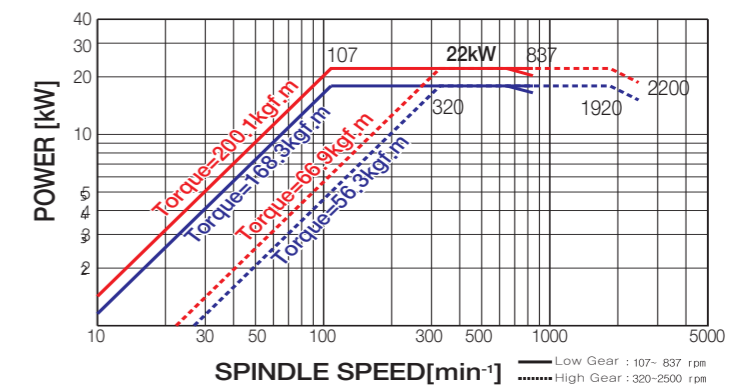

PL 35/35M/40 a compact, ultra precision Turning Center, combined with SMEC's advanced technological features.

Spindle speed
2,500 rpm (PL 35/35M)
2,000 rpm (PL 40)

Spindle motor(30min/cont.)
22/18.5 kW

Rapid traverse(X/Z)
12/15 m/min (PL 35/40)
20/24 m/min (PL 35M)

Feed motor(X/Z)
3/4 kW (PL 35)
4/7 kW (PL 35M)

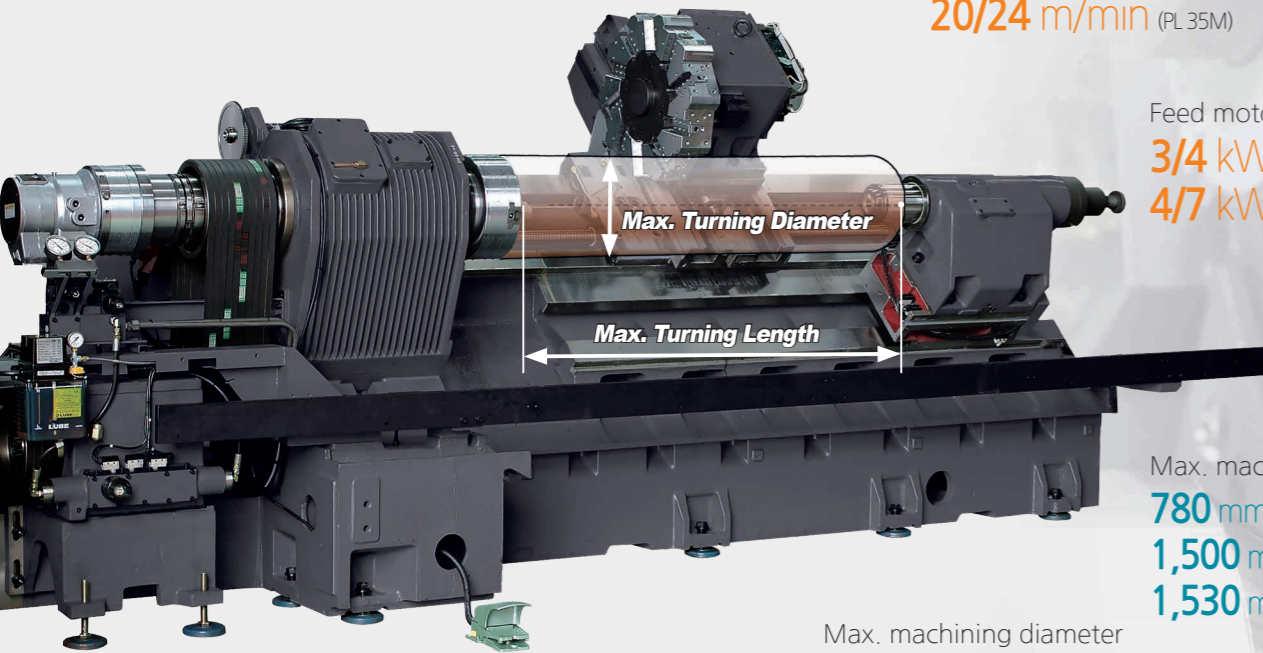

Max. machining length
780 mm (PL 35/40)
1,500 mm (PL 35LM)
1,530 mm (PL 35L/40L)

Max. machining diameter
420 mm (PL 35)
500 mm (PL 35M/40)

Highly Reliable and Rigid Structural Design

- One piece Meehanite casting with heavily ribbed torque tube design
- Rigid bed supports for powerful cutting
- Excellent vibration dampening and thermal displacement design

PL 35, 40 (High Speed Hydraulic Turret)

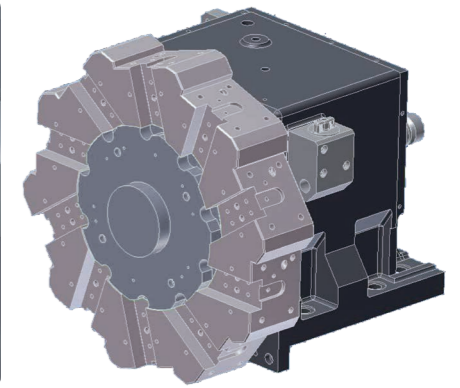
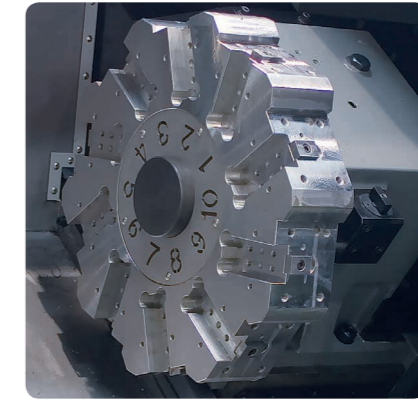

Indexing Time Number of tool positions
0.25 sec **10 stations**

High Speed, Heavy Duty Hyd. Index Turret

Driven by a high torque hydraulic index motor, the 10-station heavy-duty turret can accept tools on both left and right side of each station. Turret indexing (repeatability ± 0.005) is non-stop, bi-directional with a fast 0.25 second next station index time. A large diameter (Ø250) Curvic coupling with 6,377kgf clamping force enables precision as well as heavy-duty cutting.

PL 35LM (BMT High Speed Turret)

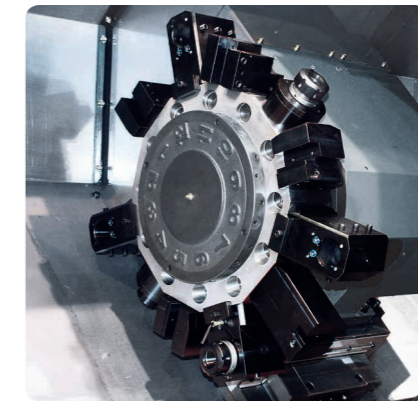

Turret Torque Diagram

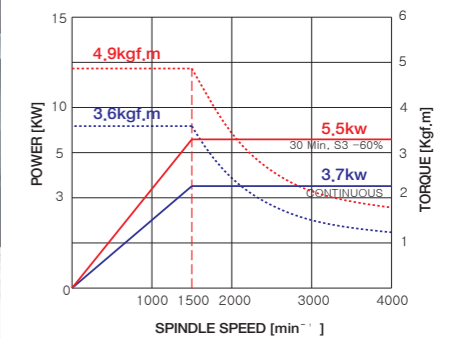

Indexing Time Number of tool positions Milling Spindle Speed Tool Holder
0.25 sec **12 stations** **4,500 rpm** **BMT 65**

BMT Milling Turret (M Type)

PL35MC is equipped with standard 12-station BMT turret capable of accepting rotary tools at any station, providing flexible machining thru various machining operations in just one set-up. Each BMT holder is securely tightened by 4 screws, allowing the turret to perform heavy-duty cutting, milling and drilling operations. Turret indexing is non-stop, bi-directional with a fast 0.25second next station index time.



Centralized Operation Panel

The centralized operation panel with its 10.4 inch color TFT LCD monitor is able to swivel 90 degrees, providing operators with easy access to the control panel while working on the machine.

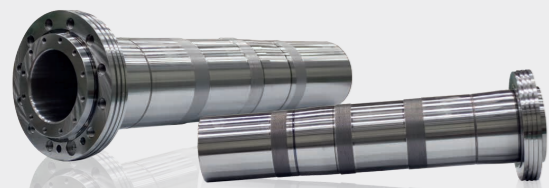

Rigid 45 degree Slant Bed

45 degree slant torque tube design bed and wide guide slide way ensure long term rigidity and machining accuracy.

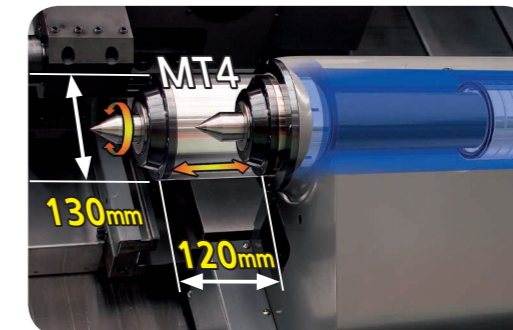
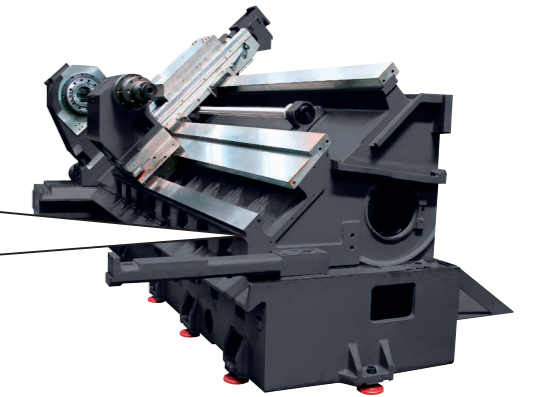
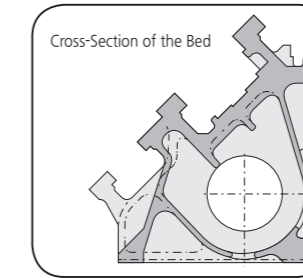

Programmable Tailstock (Carriage direct-coupled) [Std.]

The programmable tailstock body mounted is on wide guide ways to ensure rigid work piece support.

Pre-tensioned and Double Anchored Ballscrews

All axes ballscrews are pre-tensioned, heat treated and fixed by double anchors on both ends, providing ultimate rigidity and minimal thermal growth.

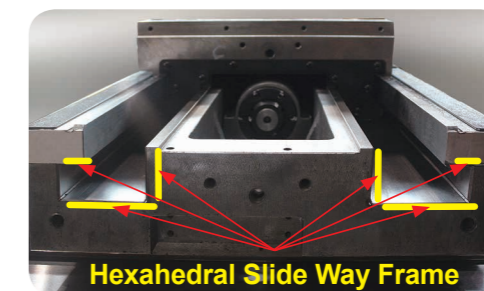
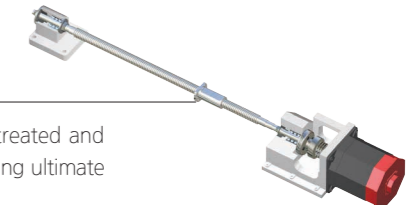

Hexahedral Slide Way Frame (X-axis)

Wide integral way is machined from the casting, induction hardened and precision ground to ensure long-term rigidity, machining accuracy and heavy-duty machining.

High Precision

Surface Roughness

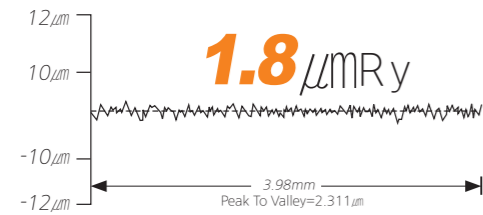

Model : PL 30

Roundness

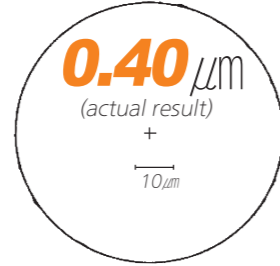

| Cutting condition | |
|-------------------|--|
| Tool | Diamond tool <nose radius 0.020 inch> |
| Material | AL150<Aluminum> |
| Cutting speed | 230 m/min |
| Feedrate | 0.05 mm/rev |
| Depth of cut | 0.1 mm |
| Outer diameter | 200 mm |
| Filter | 1-50 |

Processing Speed

Turning Performance (material:SM45C) PL 35L

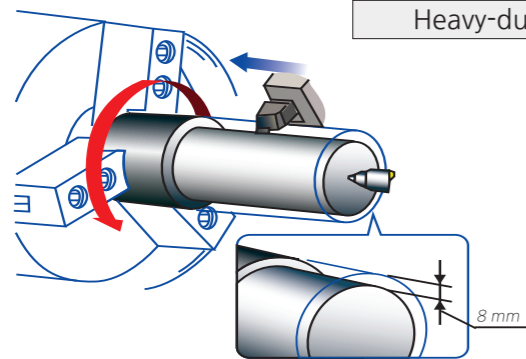

Heavy-duty cutting (O.D) <25mm×25mm qualified tool>

Spindle speed
370 rpm
Cutting speed
150 m/min
Depth of cut
8 mm <Spindle Load 50%>
Feedrate
0.4 mm/rev

Standard Accessories

Optional Accessories



Automatic Lubricator

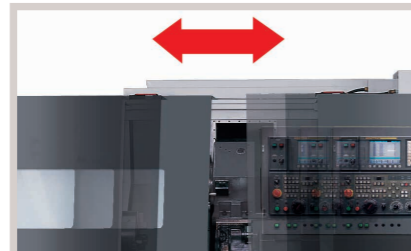

Auto Door



Tool Presetter

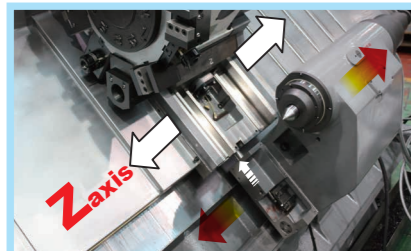

Programmable Tailstock (PL 20M/25M:STD.)



Chip Conveyor

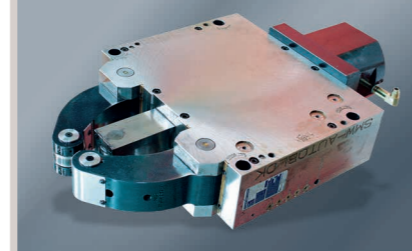

Steady Rest

Tooling System

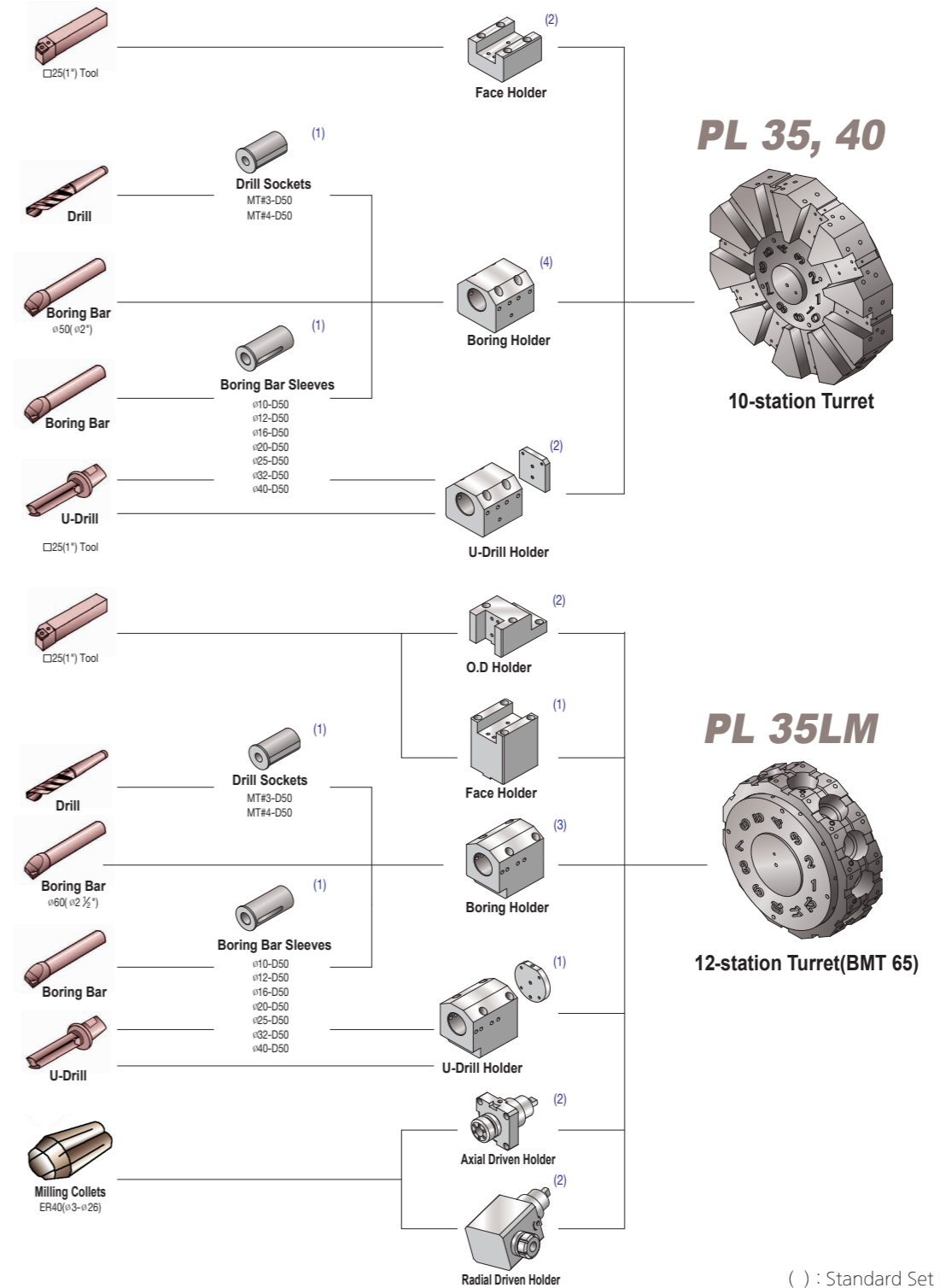

() : Standard Set Numbers

Machine Dimensions

Unit : mm

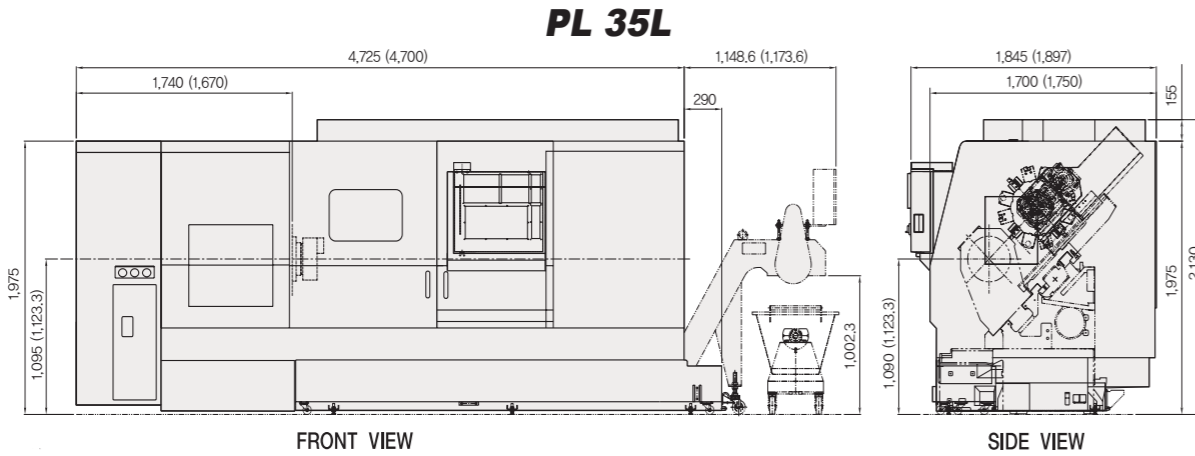

Turret Head Interference

Unit : mm

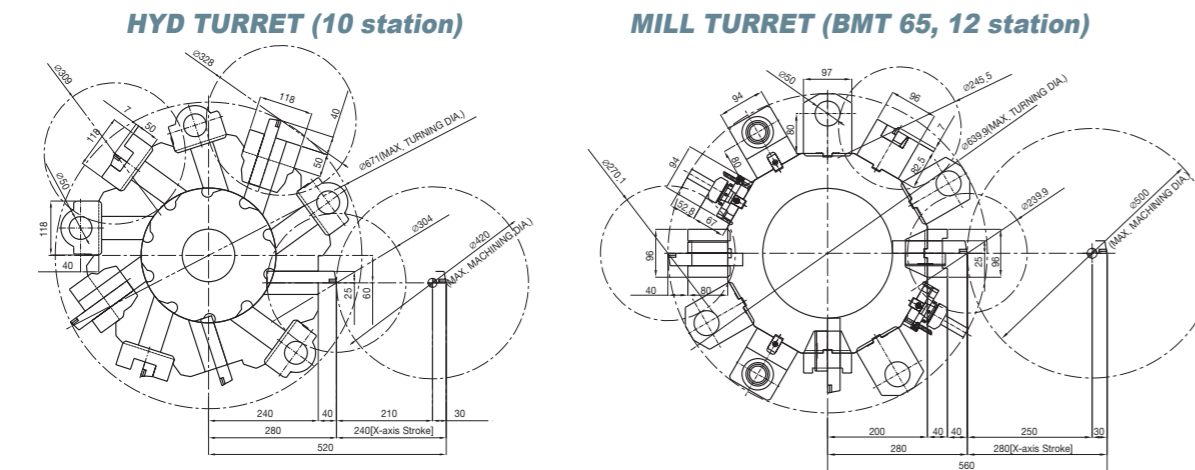

Work Range

Unit : mm

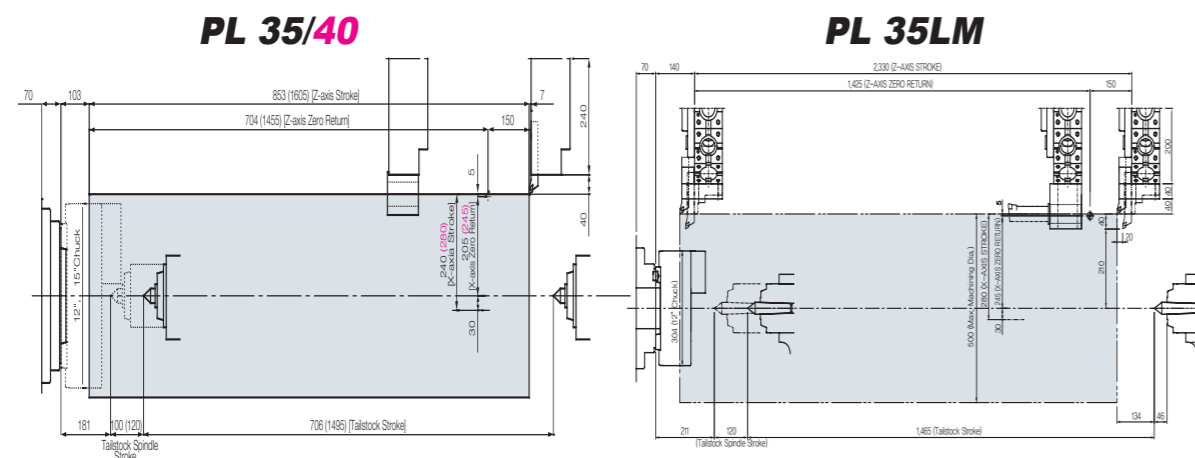

Major Specifications

| DESCRIPTION | | PL 35 | PL 35L | PL 35M | PL 35LM | PL 40 | PL 40L | |
|---------------------------|--|------------|----------------|-------------|-------------|-------------|-------------|-------------|
| Capacity | Swing over bed | mm | Ø600 | | Ø680 | | | |
| | Cross slide over Swing | mm | Ø425 | | Ø505 | | | |
| | Recom. turning diameter | mm | 420 | | 500 | | 500 | |
| | Max. machining diameter | mm | 780 | 1,530 | 780 | 1,500 | 780 | 1,530 |
| Bar working diameter | mm | Ø90 [Ø117] | | | | Ø117 | | |
| Travels | X-axis travel | mm | 240 | | 280 | | 280 | |
| | Z-axis travel | mm | 855 | 1,605 | 825 | 1,575 | 855 | 1,605 |
| Main Spindle | Spindle speed | rpm | 2,500 [2,000] | | | | 2,000 | |
| | Spindle nose | ASA | A2-8 [A2-11] | | | | A2-11 | |
| | Spindle through hole diameter | mm | 105 [132] | | | | 132 | |
| | Min. spindle indexing angle(C-Axis) | deg | - | | 0.001 | | - | |
| Turret | Number of tool stations | ea | 10 [12] | | 12(BMT65) | | 10 [12] | |
| | Shank size for square tool | mm | □25 | | | | | |
| | Shank diameter for boring bar | mm | Ø50 | | | | | |
| | Indexing time | sec | 0.25 | | | | | |
| Feed Rate | Rapid traverse (X/Z) | m/min | 12 / 15 | | 20 / 24 | | 12 / 15 | |
| | Feed per revolution | m/rev | 0.0016~500 | | | | | |
| Motor | X axis feed motor | kW | 3 | | 4 | | 3 | |
| | Z axis feed motor | kW | 4 | | 7 | | 4 | |
| | Spindle drive motor(cont./30min) | kW | 18.5 / 22 | | | | | |
| | Rotary tool spindle motor(cont./30min) | kW | - | | 3.7 / 5.5 | | - | |
| Tailstock | Tailstock travel | mm | 706 | 1,495 | 676 | 1,465 | 706 | 1,495 |
| | Quill diameter | mm | Ø130 | | | | | |
| | Quill bore taper | MT | MT-4(BUILT-IN) | | | | | |
| | Quill travel | mm | 120 | | | | | |
| ELECTRIC POWER SUPPLY | | kVA/V | 42 / 220 | | 45 / 220 | | 42 / 220 | |
| REQUIRED FLOOR SPACE(L×W) | | mm | 3,620×1,845 | 4,990×1,845 | 3,620×1,897 | 4,990×1,897 | 3,620×1,897 | 4,990×1,897 |
| MACHINE WEIGHT | | kg | 8,000 | 9,000 | 8,300 | 9,300 | 8,200 | 9,200 |
| CONTROLLER | | | Fanuc Oi-TD | | | | | |

※ Design and specifications subject to change without notice.

Standard Accessories

- Coolant System
- Built-in Work Light
- Splash Guard
- Hand Tools
- 12"Hydraulic Chuck
- Soft Jaw 3 Sets
- Hard Jaw 1 Set
- Tool Holders
- Leveling Block
- Programmable Tailstock
- Door Interlock

Optional Accessories

- Chip Conveyor With Bucket
- Air Blow Unit
- 15"Hydraulic Chuck(Big-Bore)
- Steadyrest:slu-4
- Tool Presetter
- Oil Skimmer
- Gun Coolant