



# ABENE VHF-320



## ABENE VHF-320

(Option: Read out Heidenhain ND-780 incl. optical scales)

### ABENE VHF-320

Vertical/Horizontal Universal milling machine with stepless spindle speeds frequency controlled, between 55-3000 rpm. Vertical & horizontal table. Spindle power **7,5 kW**.. Movements: X = **600** mm, Y = **500** mm, Vertical Z = **450** mm.

### ABENE Milling Machine

with motorized over-arm. Large movement in X/Y and stepless spindle speeds through a 2-step gearbox gives an even more flexible and universal machine. Stepless feeds. A perfectly matched machine built from 70 years of experience.

# TECHNICAL INFO

TECHNICAL DATA	VHF-320	VHF-320 BS	UNIT
<b>TABLE</b>			
Table Horizontal	800 x 400	800 x 400	mm
T-slot	5 x 14 (1pc H7)	5 x 14 (1pc H7)	mm
Table Vertical	1225 x 320	1225 x 320	mm
T-slot	3 x 14 (1pc H7)	3 x 14 (1pc H7)	
Max Load Vert/Hor	V-400 / H-250	V-400 / H-250	Kg
<b>MOVEMENT</b>			
Longitudinal	600	600	mm
Cross	500	500	mm
Vertical	450	450	mm
Feed Stepless (Z)	50-3000 (1200)	50-3000 (1200)	mm/min
Rapid feed X,Y	3000	3000	mm/min
Rapid feed Z	1200	1200	mm/min
Feed.motor X,Y,Z	1,5	1,5	kW
<b>SPINDLE</b>			
Spindle speed	55-3000	55-3000	rpm
Spindle	ISO40 / DIN2080	ISO40 / DIN2080	
Spindle speeds n:o	Automatic	Automatic	2 Steps
Spindle Power	7,5	7,5	kW
Spindle head swivel	0-140	0-140	degrees
Spindle quill	-	75	mm
Hand wheel	-	3 (option)	mm/rev.
<b>INSTALLATION DATA</b>			
Power requirement	25/20	25/20	A/kVA
Air (if tool clamping)	6	6	Bar
Dimensions LxWxH	2200x2200x2000	2200x2200x2000	mm
Gross weight	2300	2300	kg
Net weight	2100	2100	kg

## GENERAL DIMENSIONS

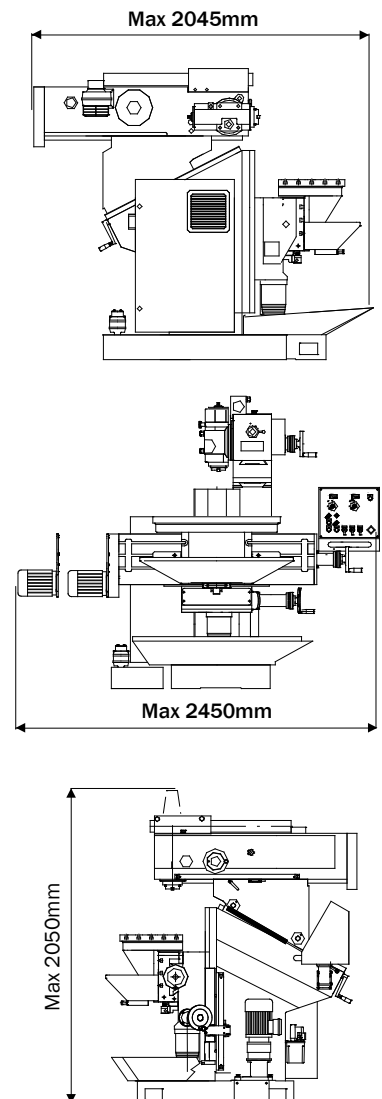

## ABENE Machine AB

Box 147, 615 23 Valdemarsvik, Sweden

Tel: +46 123 51175

Fax: +46 123 51567

E-mail: sales@abene.se

[www.abene.se](http://www.abene.se)